



**Welcome to the machine.**

# Repair Instructions

---



**MADASS 125**

## PREFACE

This repair manual serves as guideline for professional repair activities.

See the illustrated spare-parts catalog for further assistance.

All figures, dimensions and descriptions correspond to the state of the version concerned. All changes are reserved in the interest of further development of the construction models.

See also the "technical information", which provides data about technical changes implemented after this repair manual was sent to the printer .

The technical information is intended for master mechanics, since its careful and constant observation is a requisite for preserving the operability of the individual assemblies of the motorcycle.

Apart from such information, the usual basic safety rules that apply to the repair of motorcycles must be observed.

Use the tools provided for in the "Motor" section.  
The use of unsuitable tools may adversely affect engine operability.

This manual is provided only for internal use within the Peirspeed organization.  
It may not be reproduced or made available to third parties.

*Use only original MadAss125 spare parts.*

<b>TABLE OF CONTENTS</b>	<b>Page</b>
<b>TECHNICAL DATA</b>	
Engine, ignition system, carburetor, power transmission	4
Chassis, lubricants and operating fluids, electrical equipment, dimensions and weights	5
<b>SERVICE DATA</b>	
Tightening torques for inspection plan	6
Spare parts for inspection plan	7
Inspection plan	8
<b>GENERAL NOTES</b>	
<b>TORQUE VALUES</b>	
Torque values engine and frame	10
Torque values general	11
<b>MAINTENANCE</b>	
Spark plug	12
Valve clearance	13, 14
Carburetor idle speed	14
Air cleaner	15
Adjusting the clutch lever play	16
Checking, adjusting the drive chain	17
Brake system	18, 19, 20, 21
Frontwheel	22
Rearwheel	23
Wheel bearings	24
<b>LUBRICATION SYSTEM</b>	
Service information	25, 26
Troubleshooting	26
Engine oil	27
Engine oil filter cleaning	27, 28
Oil pump removal	28
Oil pump inspection and installation	29, 30
<b>FUEL SYSTEM</b>	
Service information	31
Troubleshooting	31
Carburetor throttle valve removal, inspection and installation	32, 33
Carburetor removal, inspection and installation	33, 34, 35, 36, 37
Fuel cock	38
<b>ENGINE DISASSEMBLY / ASSEMBLY</b>	
39	

<b>TABLE OF CONTENTS</b>	<b>Page</b>
<b>CYLINDER HEAD / VALVES</b>	
Service information	40
Troubleshooting	41
Camshaft removal, inspection	42
Cylinder head removal	43
Cylinder head inspection	44, 45
Valve guide, valve seat inspection, refacing	46, 47, 48, 49
Cylinder head assembly	49, 50
Cylinder head installation	51
Cam shaft installation	52, 53
Cylinder compression	53
<b>CYLINDER / PISTON</b>	
Service information	54, 55
Troubleshooting	55
Cylinder removal, cylinder inspection	56
Piston removal, piston, piston ring inspection	57, 58
Connecting rod inspection	58
Piston ring installation, piston installation	59
Cylinder installation	60
<b>CLUTCH / GEARSHIFT / LINKAGE</b>	
Service information	61
Troubleshooting	61
Clutch removal	62, 63
Clutch disassembly	64
Clutch inspection	65, 66
Clutch assembly	66, 67
Gearshift disassembly and assembly	68, 69
Clutch installation	70, 71
<b>ALTERNATOR / CAM CHAIN TENSIONER</b>	
Service information	72
Troubleshooting	72
Alternator, flywheel removal	73
Cam chain tensioner removal, inspection and installation	73

<b>TABLE OF CONTENTS</b>	<b>Page</b>
<b>TRANSMISSION / CRANKSHAFT / KICK STARTER</b>	
Service information	74
Troubleshooting	74
Crankcase separation	75, 76
Crankshaft inspection	77
Timing sprocket replacement	77
Kick starter disassembly and reassembly	78
Transmission disassembly and inspection	79
Shift drum disassembly, transmission bearing inspection	80
Crankcase bearing replacement	81
Transmission assembly	81, 82
Crankcase assembly	83
<b>ELECTRICAL SYSTEM</b>	
Fuse	84
Battery, charging battery	85
Commissioning battery	86, 87
Cockpit, speedometer adjustment	88
Speedometer battery change	89
Changing bulbs	90
Assembly of indicator, light bulbs	91
Adjusting the headlamps	92
<b>IGNITION SYSTEM</b>	
Schematic	93
Service information	94
Troubleshooting	94
CDI unit inspection	95
Ignition coil inspection	96
Alternator coil inspection	97
Ignition timing inspection	97
<b>WIRING DIAGRAM</b>	
Wiring diagram	98
<b>TROUBLESHOOTING</b>	
Engine	99, 100, 101, 102
Electric	103, 104
Battery	105

## TECHNICAL DATA

<b>Engine type</b>	FY152FMI
Construction	One cylinder 4-stroke petrol engine
Valve steering	1 overhead cam with rocker arms
Valve	2 valve
Valve clearance, cold	intake + exhaust 0.05mm-10.05mm
Piston displacement	119.70 cm <sup>3</sup>
Bore	52.40 mm
Stroke	55.50 mm
Compression ratio	9.3:1
Lubrication system	forced oil lubrication
Cooling	air cooled
Maximum net power output	6.50kw/7,500rpm
Maximum net torque	8.5 Nm at 5,400rpm
Air-filter	dry foam
Type of starter	electric starter / kick starter
<b>Ignition system</b>	transistorized ignition system with electronic ignition control (CDI)
Ignition timing	15 ° before TDC at 1,900rpm/ 30 ° before TDC at 3.500 rpm
Pickup coil resistance	110-130 Ohm (bl/w-ground)
Ignition coils resistance	Primary 550-570 Ohm
Spark plug	NGK CR7 HSA electrode gap 0.7- 0,8 mm
<b>Carburetor</b>	FYZ22PA-S3P
Main jet #	94
Idle jet	40
Jet needle setting groove	3 rd from top
Mixture regulation screw	Initial opening 1.75~2 turns out
Idle speed	1,500+/-100rpm
Float level	18mm - 0.5mm
Throttle cable free play	1,0 - 2,0 mm
<b>Power transmission</b>	
Clutch	Wet multi-plate type
Gear box	4-speed constant mesh, foot operated
Gear ratios	1. gear = 2.833 (34/12)
	2. gear = 1.706 (29/17)
	3. gear = 1.238 (26/21)
	4. gear = 0.958 (23/24)
Primary transmission ratio	3.722
Chain pinion	16 teeth
Sprocket	46 teeth
Drive chain	428, 112 links

## TECHNICAL DATA

<b>Chassis</b>	
Motorbike version:	Type 646
Frame:	Center-type frame made of tubular steel
Front suspension:	Telescopic fork $\varnothing$ 37 mm , hydraulic shock absorption, travel 100 mm
Rear suspension:	Mono shock absorber, travel 65 mm
Wheels:	Light metal (Alu) Front rim size: = 1,85 x 16" Rear rim size: = 2,50 x 16"
Tires:	Front = 90/90-16 200 kPa                      Rear = 120/80-16 250 kPa
Tire pressure solo driver Tire pressure with pillion driver	Front = 29 rear = 36 psi Front = 32 rear = 39 psi
Brakes, front Minumim lining thickness	Disc brake $\varnothing$ 260 mm, hydraulic two piston floating caliper 2,5 mm
Brakes, rear Minumim lining thickness	Disc brake $\varnothing$ 215 mm, mechanical two piston caliper 1,5 mm
<b>Lubricants and operating fluids</b>	
Fuel tank capacity	1,22 gal, including 0,09 gal reserve
Fuel	Unleaded fuel min. 93 octane
Telescopic-fork oil	Viscosity SAE 10 W
Filling quantity per fork tube	180 cm <sup>3</sup>
Engine oil Filling quantity	SAE 15 W 40 mineral oil API (SG or higher) 0.9 litres
Brake fluid	DOT 4
<b>Electrical Equipment</b>	
Generator	12 V 120 W
Charging coil resistance	0,6-0,9 Ohm
Regulator voltage	13,0-14,0 V
Battery	12 V 6 Ah MF
Fuse:	15 A
Lights - Headlight - Position light - Instrument lights  - Brake/rear light: - Turn signal light	Low beam 2x 12V 55W 12 V 5W Direction-indicator 12V 3W Change over gear 12 V 3W Cockpit 12 V 3W 12 V 21/5W 12V 21W
<b>Dimensions and weights</b>	
Overall length:	1840 mm
Width across handlebars without rear view mirror	760 mm
Maximum height	1035mm without rear view mirror
Wheel base	1235 mm
Seat height	865 mm
Weight empty	100 kg
Max. transport weight allowed	200 kg
Max. permitted total weight	300 kg

## SERVICE DATA

Tightening torques for inspection plan	Nm
Engine	
Cylinder head nuts and bolts	10-12
Cam chain tension adjuster bolt	25-28
Crankcase cover bolts	10-12
Manifold bolts	10-12
Clutch lock nut	40-45
Generator rotor nut	40-45
Engine oil drain plug	22-25
Valve cover lock	10-12
<b>Chassis</b>	
Rear-wheel axle nut	50-60
Front-wheel axle nut	45-55
Swing axle nut	45-55
Disc brake screws	12-14
Front brake calliper bolts	60-65
Rear brake calliper bolts	30-35
Handle bar holder bolt upper	22-25
Rear shock mounting bolts	38-42
Exhaust pipe mounting nuts	10-12
Engine mounting bolt upper / below	33-35
Sprocket bolts	12-14
Headlight fastening	10-12



## SERVICE DATA

### Spare parts for inspection plan

part no	Description	Q'ty	1.000 km	4.000 km	8.000 km	12.000 km
43235-FYBQ-300	Brake pad (rear)	2		X	X	X
46630-FYBQ-000	Brake pad (front)	2		X	X	X
V241201-FYIJ-0000	Core cleaner	1		X	X	X
18543-FY20-000	Gasket, air cleaner	1		X	X	X
90701-30003-002	O-gasket valve cover	2	X	X	X	X
90713-FYXF-000	O-gasket cover side hole upper	1	X	X	X	X
90727-FYXF-000	O-gasket cover side hole	1	X	X	X	X
E000002-FYIF3-0000	Spark plug	1			X	
90301-12020-15AL0	Gasket drain plug	1	X	X	X	X
	Engine oil SA 10W40	1	0.9 Liter	0.9 Liter	0.9 Liter	0.9 Liter
23682-FYIF3-000	Sprocket 16T	1	Replace if necessary			
GB/T894.1-17-0	Spline gear driven	1	Replace if necessary			
41201-FY20-000	Chain sprocket 428/46	1	Replace if necessary			
40520-FY20-000	Chain 428-112B	1	Replace if necessary			
V171030-FY20-0000	Front tire(tubeless, 90/80-16)	1	Replace if necessary			
V172030-FY20-0000	Rear tire(tubeless, 120/70-16)	1	Replace if necessary			

## SERVICE DATA

Inspection plan						
<b>I = Inspection, retighten, adjust, replace if necessary, or grease</b> <b>W= Change</b> <b>R = Clean</b> <b>S = Grease</b>						
	Maintenance Kilometers	Delivery	1.000	4.000	8.000	12.000
	Months	NEW	1	4	8	12
Component Assembly	Servicing Tasks					
Valves	Check and adjust valves if necessary	I	I	I	I	I
Spark plug	Check condition and accordingly clean or replace	I	I	I	W	I
Air filter	Clean filter and housing		R	R	R	R
	Replace paper filter		I	W	W	W
Carburetor	Check and adjust idle and cold start	I	I	I	I	I
	Throttle cable	I	I	I	I	I
Fuel filter	Clean (petcock)		R	R	R	R
Fuel hoses	change at least every 4 years		I	I	I	I
Engine oil	Change (operating temperature)	I	W	W	W	W
Exhaust system	Check for leads and repair if necessary	I	I	I	I	I
Brakes	Check brake function and brake fluid	I	I	I	I	I
	Check and replace brake pads	I	I	W	W	W
	Adjust rear brake	I	I	I	I	I
Brake fluid	Change	<b>change every 2 years</b>				
Brake hoses	Check and renew min. every 4 years	I	I	I	I	I
Clutch	Check and adjust	I	I	I	I	I
Rear suspension	Check, retighten, replace if necessary	I	I	I	I	I
Tires	Check general condition and profile depth and replace as necessary	I	I	I	I	I
	Check air pressure	I	I	I	I	I
Wheels	Check for damage, balance	I	I	I	I	I
Steering and bearings	Check and adjust free play	I	I	I	I	I
Front forks	Check general condition as well as for leaks and repair if necessary	I	I	I	I	I
Chain	Check adjustment and condition and grease, adjust and renew if necessary	I/S	I/S	I/S	I/S	I/S
Side stand	Check, grease, repair if necessary	I/S	I/S	I/S	I/S	I/S
Nut and bolt tightness	Check tightened to the correct torque settings	I	I	I	I	I
Cables	Check for damage and smooth operation, if necessary replace	I	I	I	I	I
Headlight	Check and adjust	I	I	I	I	I
Battery	Check, recharge if necessary	I	I	I	I	I

**GENERAL NOTES**

**Gaskets, seal rings and O-rings**

- Gaskets, seal rings and O-rings must generally be replaced when overhauling the engine. The sealing faces must be thoroughly cleaned.

**Lock washers and split pins**

- After removal replace all lock washers (1) and split pins. After tightening the nut, lock washer (1) must be bent up against the side of the nut.

**Bearings and radial seals**

- When assembling bearings (1) make sure that manufacturer name or number point to the outside. Lubricate the bearings with oil.

**ATTENTION**

**Do not use compressed air to dry the bearings since this could damage the surface of the bearings.**

- When assembling radial seals (1) make sure that manufacturer name or number point to the outside. Apply a thin coat of light viscosity engine oil to the seal lips.

**Circlips**

- Circlips must be thoroughly inspected before installation.
- Piston pin circlips must not be assembled again.
- Warped circlips must be renewed.
- When assembling a circlip (1) make sure that the sharp edged side (2) is positioned opposite the side subjected to the force (3) applied to the circlip. See cross-sectional drawing (4 = shaft).

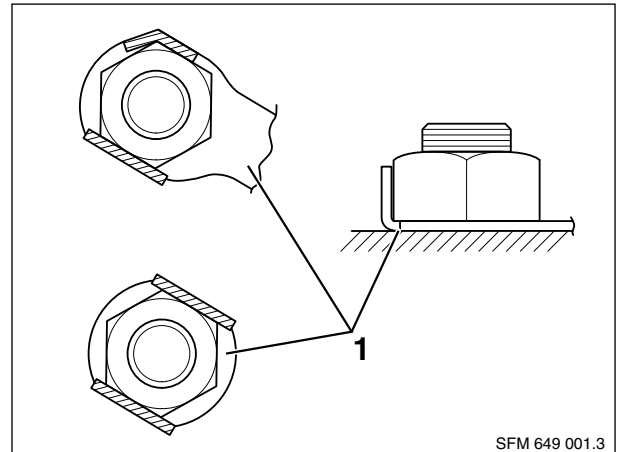

SFM 649 001.3

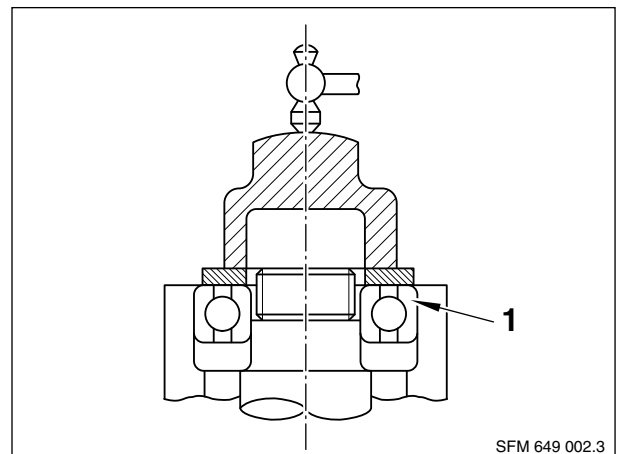

SFM 649 002.3

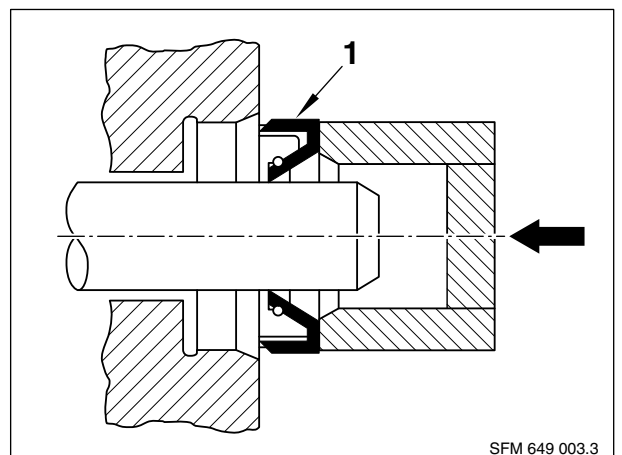

SFM 649 003.3

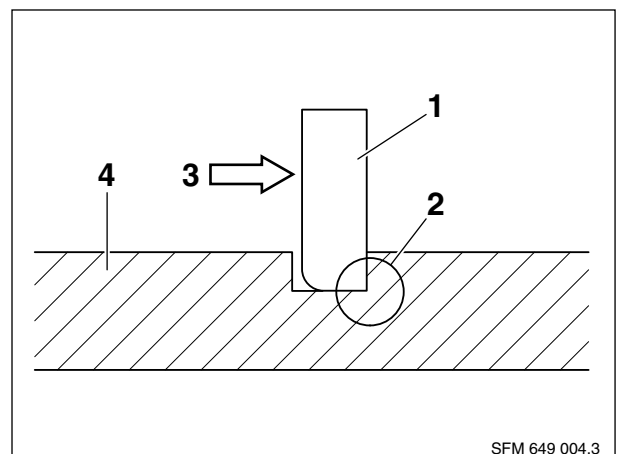

SFM 649 004.3

## TORQUE VALUES

TORQUE VALUES ENGINE			
Item	Q'ty	Thread Dia mm	Nm
Clutch lock nut	1	14	40-45
Flywheel nut	1	10	42
Cam sprocket bolt	3	5	9
Valve adjuster lock nut	2	5	9
Cylinder head nut	4	6	10-12
Cylinder head bolt	2	6	10-12
Cam chain guide roller pin bolt	1	6	10
Intake manifold bolt	2	6	10-12
Exhaust pipe joint nut	2	6	12
Shift drum stopper arm bolt	1	6	10
Shift drum stopper plate bolt	1	6	17
Shift spring pin bolt	1	8	30
Oil drain bolt	1	12	22-25
Cam chain tensioner sealing bolt	1	14	25-28
Cam chain tensioner pivot bolt	1	8	16
Shift drum bolt	1	6	12
Crankcase cover bolt	11	6	10-12
Drive sprocket bolt	2	6	12-14

TORQUE VALUES FRAME	
Connection	Nm
Handle bar holder	22-25
Fastening screws for upper fork bridge	25-28
Fastening screws for lower fork bridge	38-42
Screw plug for fork pipe	40
Closing nut of control-head bearing	40
Brake shoe, front	60-65
Brake shoe, rear	30-35
Brake disk on wheel hub, front	12-14
Brake disk on wheel hub, rear	12-14
Brake pipe connection	20-25
Ventilating valve on calliper	10-12
Screws for brake lining, rear	22-25
Footbrake lever on frame	25-28
Gear pedal	25-28
Footrest support, front	25
Footrest support, rear	25
Chain wheel to hub	10-12
Engine fastening	33-35
Exhaust pipe nuts	10-12
Front-wheel axle	45-55
Rear-wheel axle	50-60
Swing axle	45-55
Telescopic leg	38-42
Side standard	40

## TORQUE VALUES

<b>TOURQE VALUES FOR ENGINE/CLUTCH/GEARBOX/FRAME</b>	
<b>Tightening torques, gernal</b>	<b>Nm</b>
Srew connection M5	5-6
Srew connection M6	8-10
Srew connection M8	22-25
Srew connection M10	38-42
<b>Tightening torques for plastic connections</b>	<b>Nm</b>
Srew connection M5	3-5
Srew connection M6	5-7
Srew connection M8	13-15

**MAINTENANCE****Spark plug****Recommended spark plug: NGK CR7 HSA****CAUTION****Check or change the spark plug only when the engine is cold.**

Pull the spark plug connector (1).

Unscrew the spark plug (2).

Clean any dirt from around the spark plug base.  
Visually inspect the spark plug electrodes for wear.  
The center electrode (4) should have square edges and the side electrode (3) should have a constant thickness.  
Discard the spark plug if there is apparent wear or if insulator is cracked or chipped.  
Measure the spark plug gap using a wire-type feeler gauge.

Check the electrode gap (0,7-0,8 mm), replace the plug if it is severely burnt away.

Adjust the gap by bending the side electrode carefully. With the plug washer attached, thread the spark plug in by hand to prevent cross threading. Tighten the spark plug with a spark plug wrench to compress the plug washer.

**Torque 20 Nm.**

Plug in the connector (1).

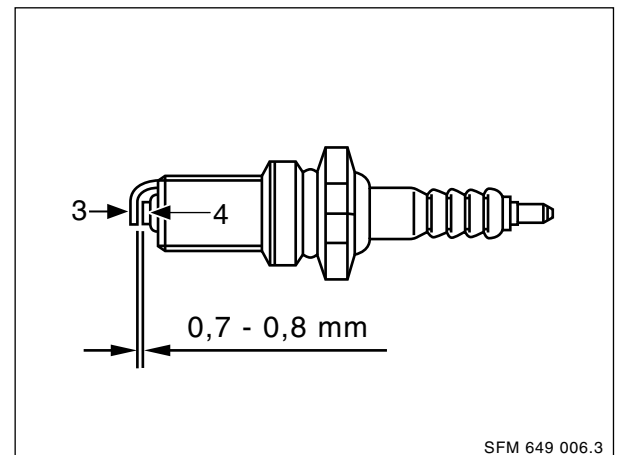
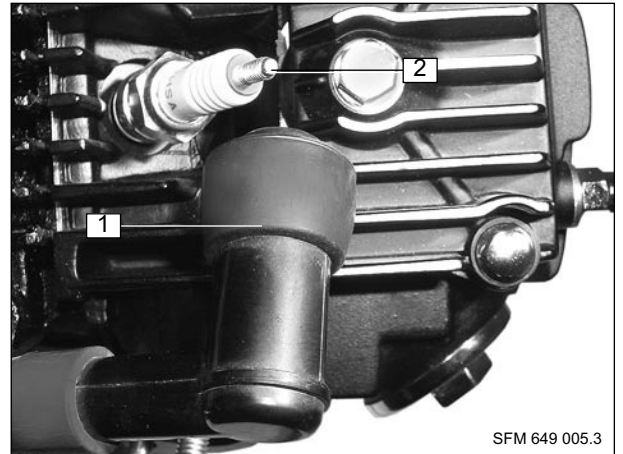

**MAINTENANCE**

**VALVE CLEARANCE**

**NOTE**

Adjust the valve clearance while the engine is cold (below 35°C)

Remove inspection plugs (1 and 2) of the left side engine cover.

Remove the valve adjuster covers (3).

Rotate the crankshaft counterclockwise and align the "T" mark with index mark on the left crankcase.

Make sure the piston is at TDC on compression stroke.

Check the valve clearance by inserting a feeler gauge between the adjusting screw and valve stem.

**VALVE CLEARANCES (Cold):**  
**IN and EX: 0.05 ± 0.02 mm - 0.08 ± 0.02 mm**

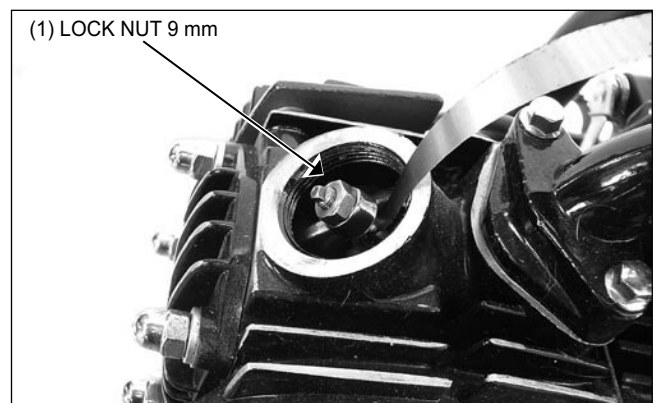
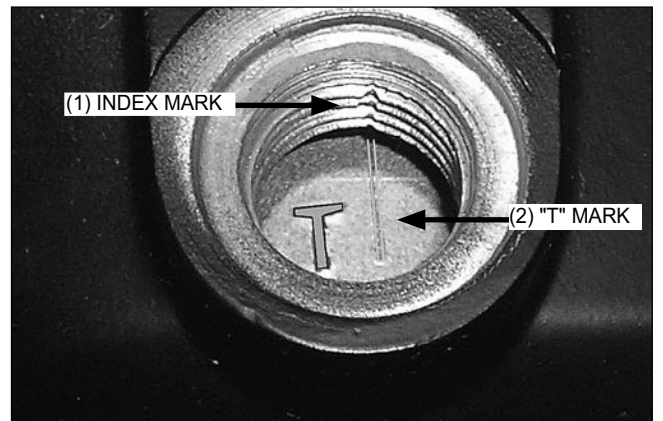
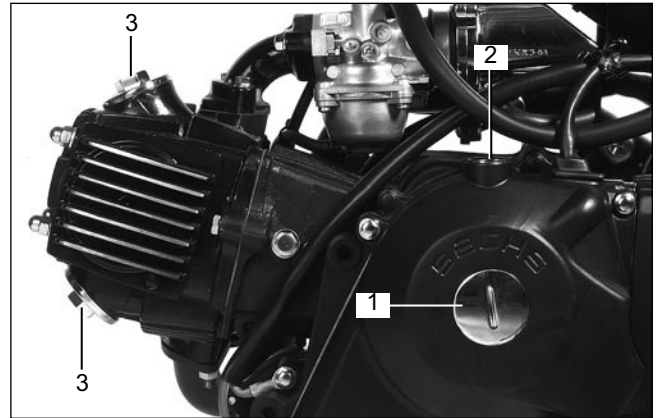

## MAINTENANCE

Adjust by loosening the lock nut and turning the adjusting screw until there is slight drag on the feeler gauge. Hold the adjusting screw and tighten the lock nut. Recheck the valve clearances.

### TOOLS:

Valve adjust wrench, 9 mm

Valve adjuster B

Install the valve adjuster covers and the inspection plugs.

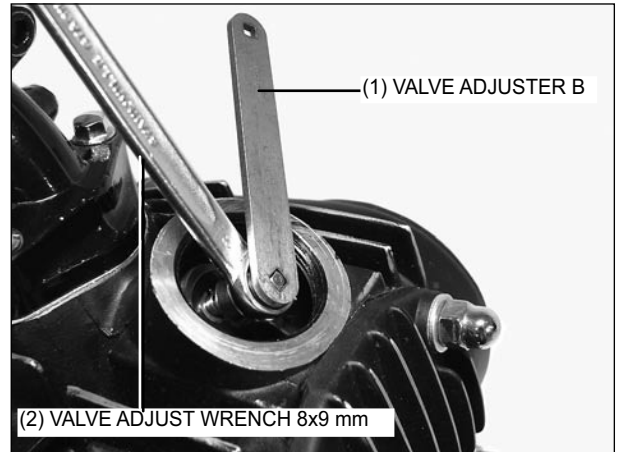

## CARBURETOR IDLE SPEED

### NOTE

Inspect and adjust the idle speed after all other engine maintenance items have been performed and are within specifications.

The engine must be warm for accurate idle speed inspection and adjustment.

Shift the transmission into neutral and place the motorcycle on its center stand on level ground.

Warm up the engine for about ten minutes and connect a tachometer.

### WARNING

**If the engine must be running to do some work, make sure the area is well-ventilated. Never run the engine in an enclosed area. The exhaust contains poisonous carbon monoxide gas that may cause loss of consciousness and lead to death.**

Turn the throttle stop screw as required to obtain the specified idle speed.

**IDLE SPEED:** 1500+/-100rpm

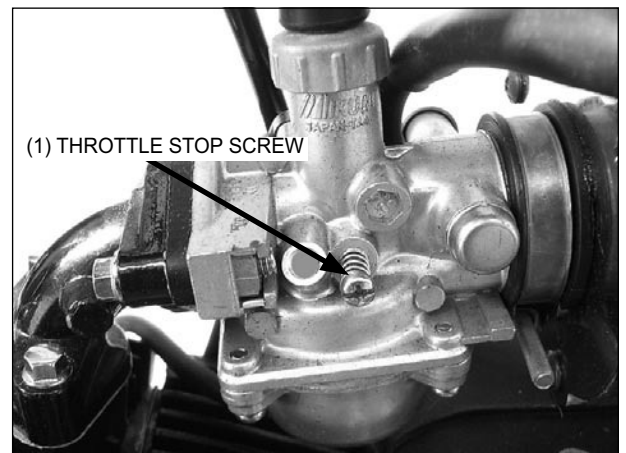



**MAINTENANCE**

**AIR CLEANER**

<b>Clean initially at</b>	<b>1.000 km</b>
<b>Replace every</b>	<b>4.000 km</b>

**Remove the air cleaner**

- Unscrew the screws (1) of the manifold and take off the carburetor with the air cleaner.
- Unscrew the clamp (2) and remove the air cleaner (3) from the carburetor.

**Opening the air filter**

- Remove the three screws (4).
- Take off the cover (5).
- Clean the filter case and filter element (6) or replace if necessary.

**NOTE**

Before installation, check the O-rings (7) for damage and correct position.

Assembly of the cleaned or new filter element takes place in reverse order of removal.

**Tightening torque**

**screw (1)      10-12 Nm**  
**screw (4)      6 Nm**

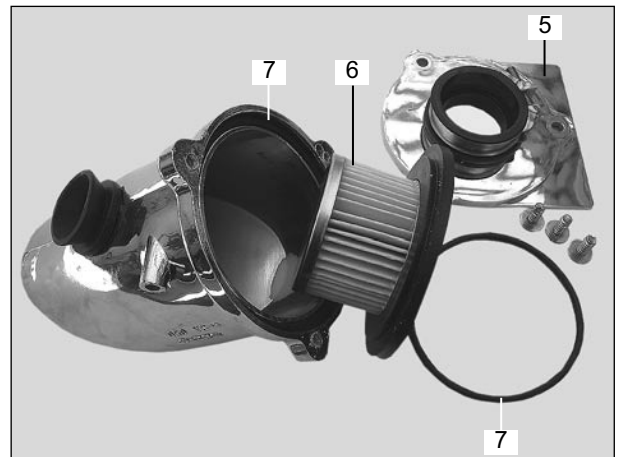
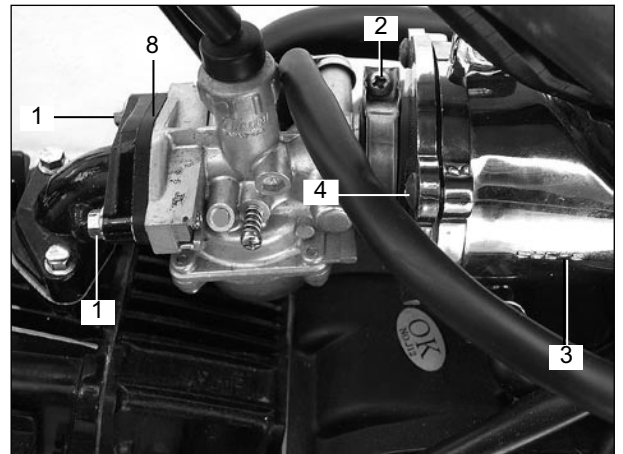

**MAINTENANCE**

**Adjusting the clutch lever play**

**CAUTION**

If you drive with no clutch lever play, the clutch will be damaged.

**Check:**

- Pull the lever until there is discernable resistance.
- Measure the play. Required value:  
Standard: A = min. 3-4 mm

**Adjustment:**

- Push back protective cap (1).
- Release the lock nut (2).
- Turn setting screw (3) as required.
- Tighten the lock nut (2).
- Check the play.

**NOTE**

If the clutch play cannot be corrected with this adjustment, the following adjustment must be made.

- Release the lock nut (2).
- Tighten setting screw (3) all the way, so that the clutch cable can be made as slack as possible.
- Tighten up the lock nut (2).
  
- Remove screws (4) and take off the clutch cover (5).
- Release the lock nut (6).
- Adjust the setting screw (7) until the desired clutch lever play (A = 3-4 mm) is reached.
- Tighten the lock nut (6).
- Reassemble the clutch cover (5) with gasket.

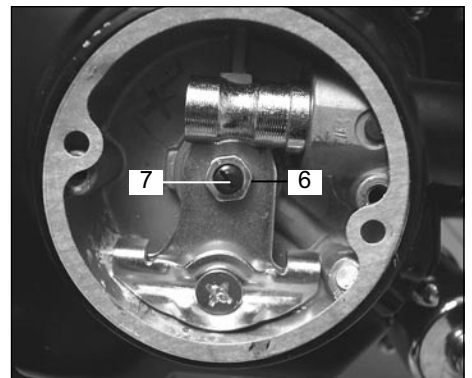
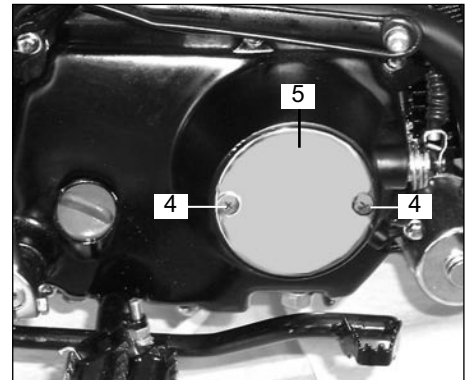
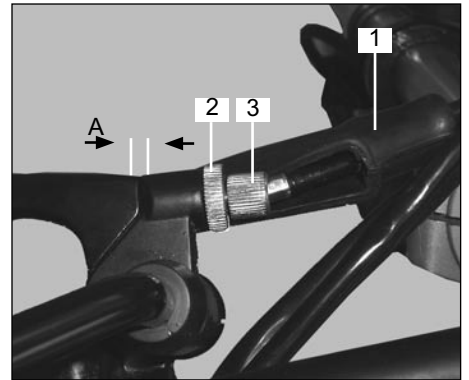

**MAINTENANCE**

**Checking, adjusting the drive chain**

**Checking the chain for wear**

**CAUTION**

**The chain, sprocket and pinion must be changed as a single unit.**

- Prop the motorbike up on the side stand.
- Hold the chain (1) at the furthest rear point of the sprocket and pull it
- With correct chain tension, it should not be possible to lift the chain higher than the teeth of the sprocket.
- If the chain can be pulled higher, chain, sprocket and pinion have to be replaced.

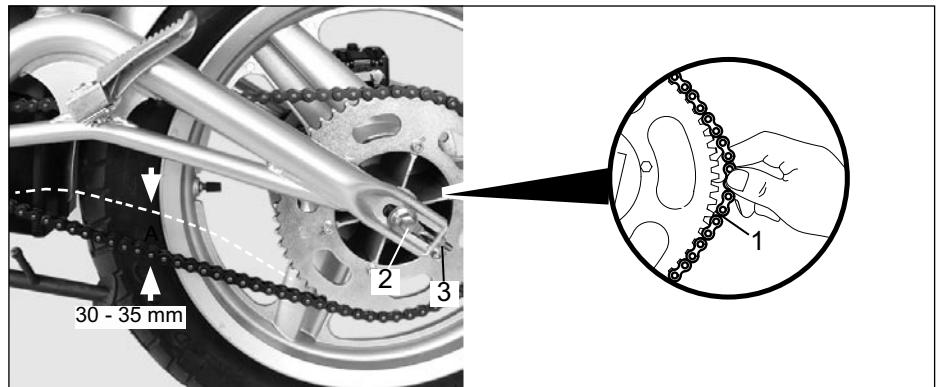

**Adjusting the chain**

**CAUTION**

**The adjustment of the chain influences the wear of chain and sprocket.**

**Too tight off an adjustment of the chain will cause bearing damages on engine and rear wheel and result in excessive wear of the chain.**

- Unscrew the axle (2).
- Adjust the setting nuts (3) evenly on both sides of the chain tensioner (rear wheel must be in line with the front wheel).
- Let rear end of the motorbike drop to the suspension limit.
- Push in the drive chain half way between sprocket and pinion. Measure the travel.

30

**Required value: A =30-35 mm**

- Tighten axle (2).
- Tighten lock nuts (3).

**Torque**

**Axle nut: 50-60 Nm**

## MAINTENANCE

### Brake system

#### Checking the brake system for leaks

- Check the brake lines for damage and correct position.
- Wipe off all screw connections of the brake lines.
- Firmly operate the front and rear brakes and shortly keep them operated.
- Check the brake lines for any leaks.
- Replace any faulty brake lines and seals/washers.

#### Checking/adjusting the front and rear brake-fluid level

#### CAUTION

**Brake fluid damages paint and plastic parts! Before filling the tank with brake fluid, check the brake lining for wear and the brake system for leaks. Only use new brake fluid of specification DOT 4. Brake fluid is exposed to high temperatures and absorbs moisture from the ambient air.**

#### NOTE

Cover the painted parts to avoid damage.

#### Checking the front brake-fluid level:

- Turn the handlebar until the line near the "LOWER" mark on the brake-fluid tank is horizontal.
- The brake-fluid level must be between the "LOWER" and "UPPER" marks.
- If air bubbles are visible: check the brake lining for wear, if necessary replenish the brake fluid.

#### Replenishing the brake fluid:

- Remove the cover (1) and the rubber gasket.
- Replenish the brake fluid up to the "UPPER" mark and reinsert the rubber gasket.
- Reinstall on the cover.

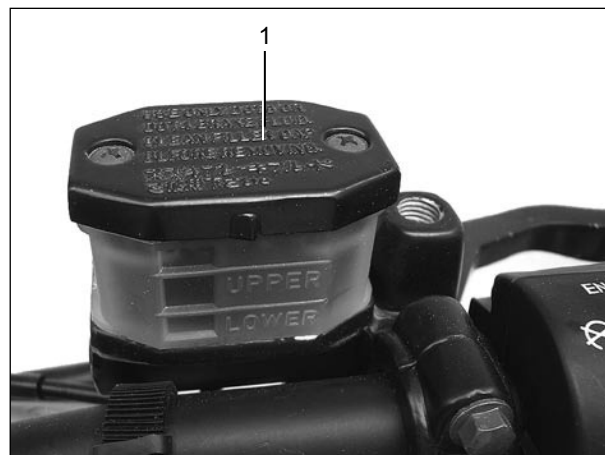

#### Checking the rear brake-fluid level:

- Park the motorbike on a flat surface.
- The brake-fluid level must be between the "LOWER" and "UPPER" marks.
- If air bubbles are visible: check the brake lining for wear, if necessary replenish the brake fluid.

#### Replenishing the brake fluid:

- Remove the cover (2) and the rubber gasket.
- Replenish the brake fluid to the "UPPER" mark and reinsert the rubber gasket.
- Reinstall on the cover.



**MAINTENANCE**

**Checking/replacing the lining of the front brakeshoes**

**Checking the lining thickness**

**CAUTION**

**Make sure the minimum lining thickness is observed.**

- Visually inspect the calliper (1).
- Check the minimum lining thickness.

**Minimum lining thickness (A): 2.5 mm**

If the thickness is less than the minimum:  
replace the brake lining (2).

- Check the brake disk for wear and wobble.

**Replacing the brake linings:**

**NOTE**

Brake linings may only be replaced in pairs.

- Remove the screws (3).
- Remove the caliper.
- Remove the holder bolts (4) from the caliper (1).
- Remove the brake linings (2).
- Check the lock plate (5) for damage.
- Insert the new brake linings and fasten them with the holder bolts.
- Reassemble in reverse order.

**Tightening torques**

**calliper screws (3): 35-38 Nm**

**Holder bolts (4): 25-28 Nm**

**WARNING - RISK OF ON-ROAD ACCIDENT**

**Operate the brakes several times, until the brake linings make contact.**

- Check the brake - fluid level and the handbrake play.
- Check the operation.

**Brake light switch**

**NOTE**

The brake light switch (6) is placed in the hand brake lever. By operating the front brake lever (7) the brake light must flash immediately.

An adjustment is not required.

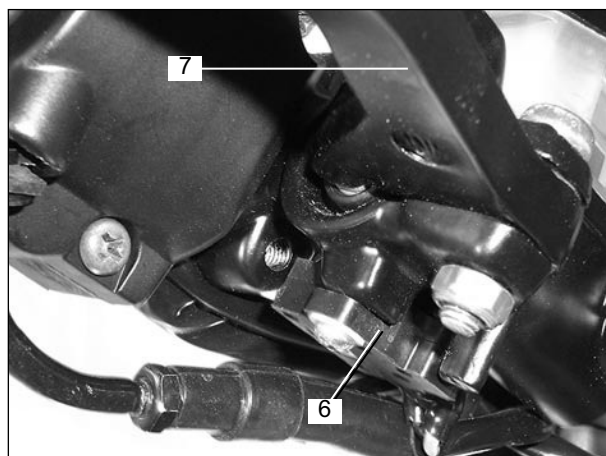
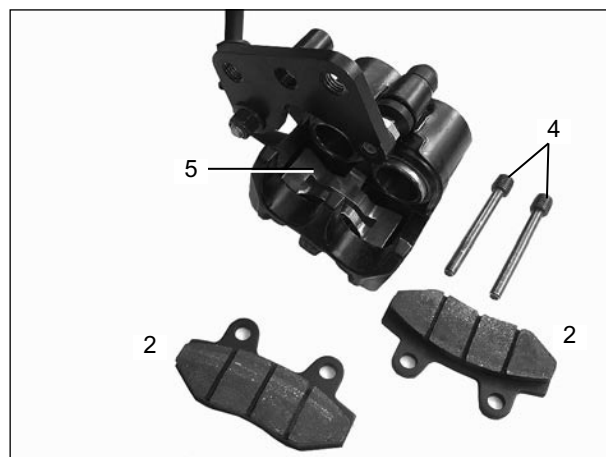
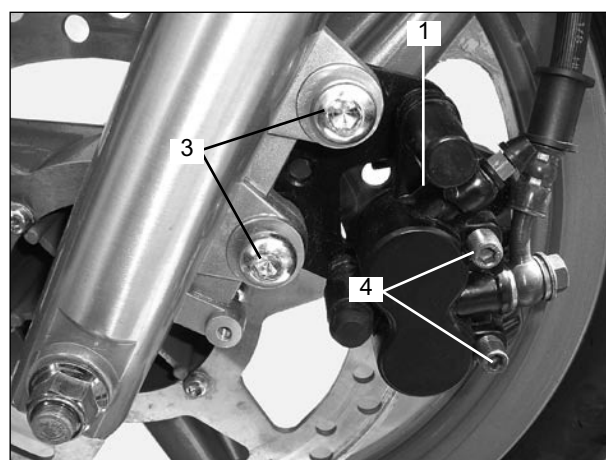
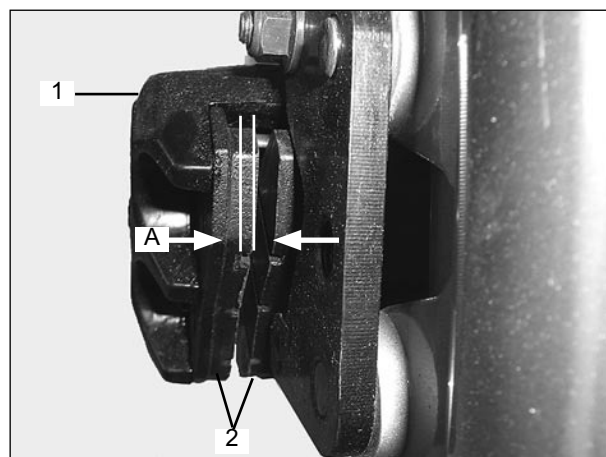

**MAINTENANCE**

**Checking/replacing the lining of the rear brake-shoes**

**Checking the lining thickness:**

**CAUTION**

The minimum lining thickness must not be fallen short of.

- Visually inspect the brake calliper (1).
- Check the minimum lining thickness.

**Minimum lining thickness (A): 1.5 mm**

If the lining thickness is less than the minimum:  
replace the brake lining.

- Check the brake disk for wear and wobble.

**Replacing the brake lining:**

**NOTE**

The brake linings may only be replaced in pairs.

Use heatproof lubricant e.g. copper paste for mechanical movable parts.

Use screw-lock e.g. Loctite 242 for brake screws.

- Unscrew the bolts (3) and remove the brake calliper (1).
- Bend back the lugs (4) of the locking plate (5).
- Unscrew the bolts (6).
- Remove the brake linings (7).
- Insert the new brake linings (7) and screw the fixation bolts (6) in the brake capillar by using a new locking plate (5).
- Lock the bolts (6) by bending the lugs (4).

**WARNING - RISK OF ON-ROAD ACCIDENT**

Allways use a new locking plate (5). Make sure that the bolts (6) are locked fail-safe.

**Tightening torques**

**Bolts (6): 25-28 Nm**

- Reassemble in reverse order.

**Tightening torques**

**Bolts (3): 30-35 Nm**

**WARNING - RISK OF ON-ROAD ACCIDENT**

Operate the brakes several times, until the brake linings make contact.

- Check the operation.

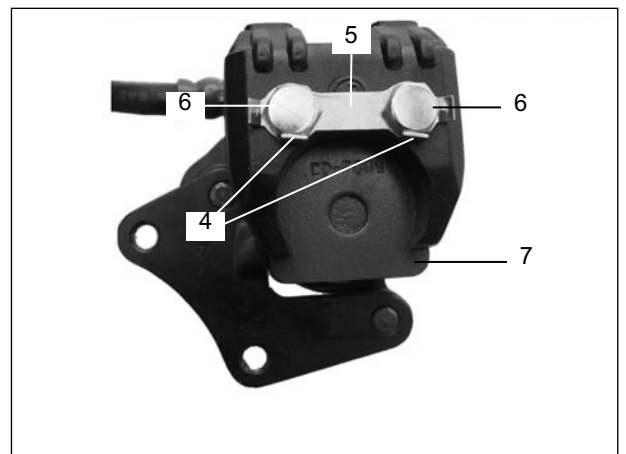
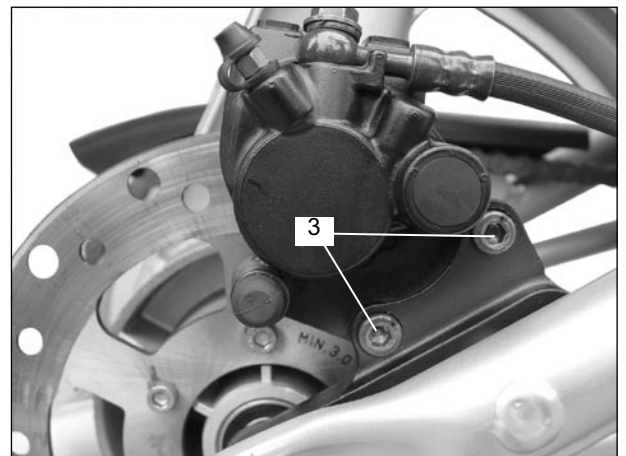
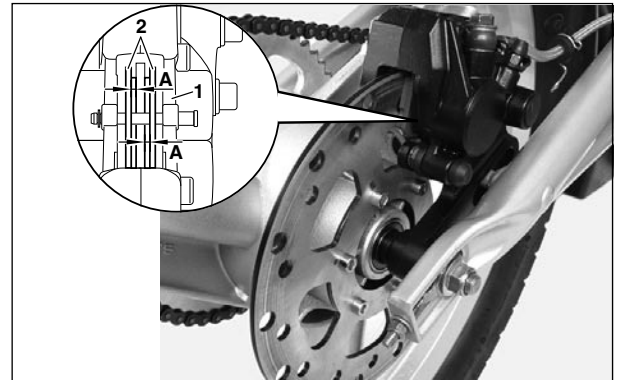

**MAINTENANCE****Setting the footbrake pedal position****NOTE**

The footbrake pedal position can be adjusted with the setscrew (1).

**WARNING**

The adjustment measurement **A** must not exceed 14 mm!

- Loosen lock nut (2) and adjust the foot brake pedal position (3) with the setscrew (1).
- Tighten lock nut (2).

**CAUTION**

A footbrake lever play that is too small will lock the rear wheel.

**Brake light switch****NOTE**

The brake light switch is placed in the rear brake pump (4).  
By operating the rear brake lever the brake light must flash immediately.  
An adjustment is not required.

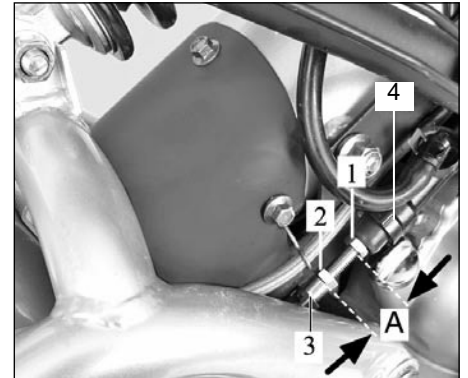

**MAINTENANCE**

**FRONT WHEEL**

**Removing the front wheel**

**CAUTION**

Take care not to damage the brake discs and linings while removing them.

Do not operate the handbrake lever after the wheel has been removed.

Protect the wheel bearings from dirt and moisture.

- Support the motorcycle so that the front wheel can move freely and the motorcycle is standing securely.
- Loosen the axle nut (1).
- Lift the front wheel and pull out the full-floating axle (2) and remove the spacer bushing (3).
- Remove the front wheel by pulling it down.

**Installing the front wheel**

**CAUTION**

Take care not to damage the brake discs and linings (4) while installing them.

- Roll the front wheel in between the fork tubes and insert the spacer bushing (3) (on the right as seen from the riding direction).
- Grease the full floating axle (2) and push it in from the right as far as it will go.
- Attach the axle nut (1) and tighten.
- Before tightening the screws, stand the motorbike on its wheels and push the telescopic forks several times to prevent twisting of the fork struts.

**Torque**

**Axle nut (1):**                      **45-55 Nm**

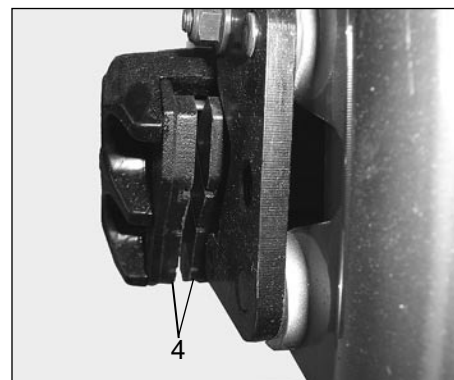
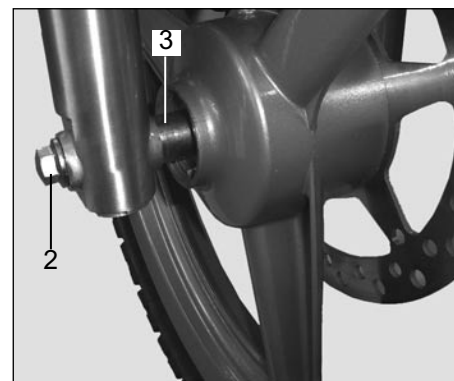
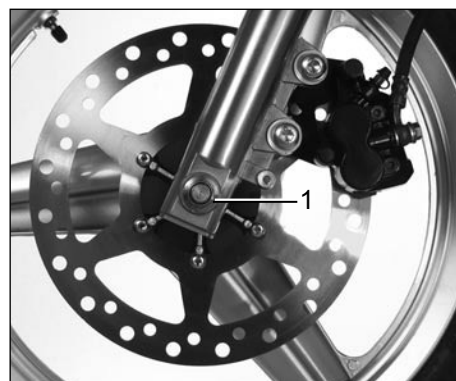



**MAINTENANCE**

**REAR WHEEL**

**Removing the rear wheel**

**CAUTION**

**Do not damage brake disc and linings during disassembly!**

**Protect the wheel bearings from dirt and moisture!**

- Support the motorbike so that the rear wheel can move freely.
- Counter the axle (4) and loosen the axle nut (1).
- Back the lock nuts on left and right-hand sides of the chain tensioner (2) completely off.
- Take off the drive chain (5).

**NOTE**

When taking off the rear wheel, make sure that the bush (3) to the left of the wheel hub is not lost.

- Lift up the rear wheel, remove axle (4) and brake counter bracket (6) with brake caliper and pull the rear wheel out towards the back.

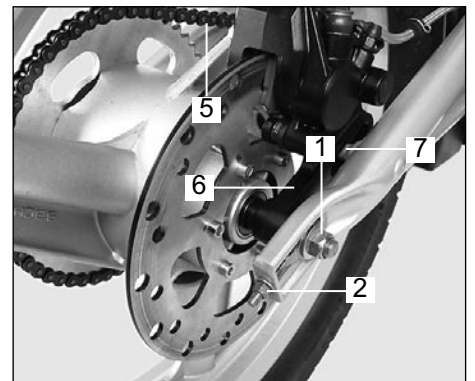
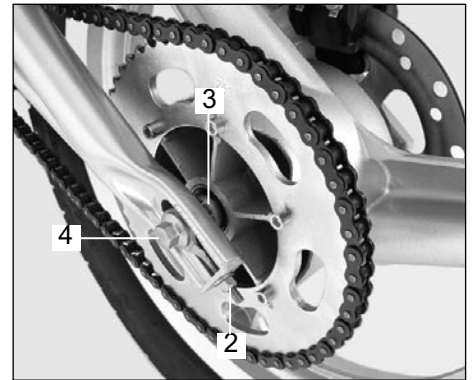

**Installing the rear wheel**

**CAUTION**

**Do not damage brake disc and linings during installation!**

- Clean and grease the axle (4).
- Assemble axle (4), chain tensioner (2), brake caliper (6) into the swing arm.

**NOTE**

Insert the brake counter bracket into the receptacle (7) of the rear suspension.

- Assemble the drive chain (5).
- Assemble the rear wheel with spacer sleeve (3) and axle (4).
- Attach the right hand chain tensioner (2) and preassemble with axle nut (1).
- Tension the drive chain.
- Tighten axle nut (1).

**Torque**

**Axle nut (1): 50-60 Nm**

**MAINTENANCE**

**FRONT WHEEL / REAR WHEEL BEARINGS**

**Removing/installing the front-wheel bearing**

**NOTE**

Heat the bearing seat to approx. 100 °C in order to facilitate removal/installation.

**Removing the wheel bearing:**

- Remove the front wheel.
- Use an internal extractor to pull the wheel bearing (1) out of the bearing seat of the wheel hub (2).

**Installing the wheel bearing:**

- Press the wheel bearing (1) into the bearing seat of the wheel hub (2).
- Install the front wheel.

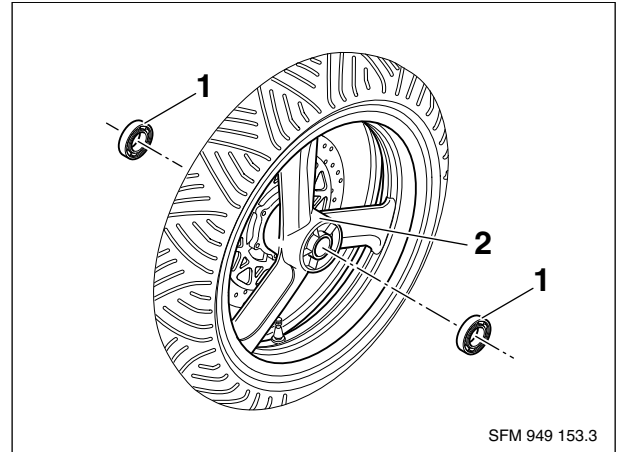

**Removing/installing the rear-wheel bearing**

**NOTE**

Heat the bearing seat to approx. 100 °C in order to facilitate its removal and installation.

**Removing the wheel bearing:**

- Remove the rear wheel.
- Remove the brake shoe support.
- Use an internal extractor to pull the wheel bearing (1) out of the bearing seat of the wheel hub (2).

**Installing the wheel bearing:**

- Press the wheel bearing (1) into the bearing seat of the wheel hub (2).
- Install the front wheel.

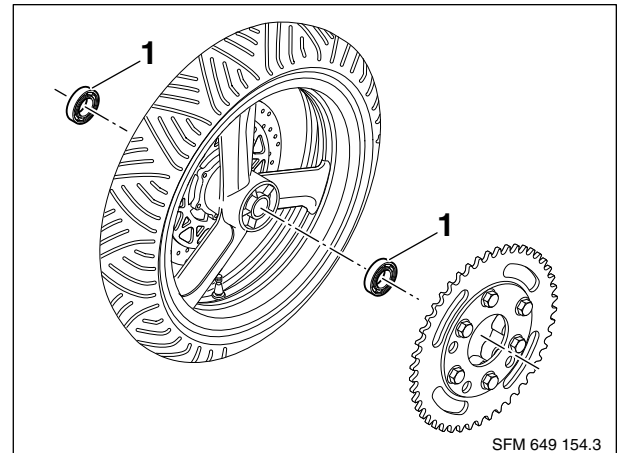

**Statically aligning the wheels**

- Clamp the relevant wheel in the aligning device.
- Rotate the wheel gently and wait until it comes to a standstill. Make a mark (1) at the low point of the tire.

**NOTE**

Always start with the smallest alignment weight.

- Turn the wheel through 90°, stop it and let it find its own position. If the mark (1) again stops at the low point of the tire, this is the heavy point and an alignment weight (2) must be installed opposite it.
- Each time turn the wheel through 90° and stop it; the wheel must remain in position, otherwise repeat the alignment procedure.

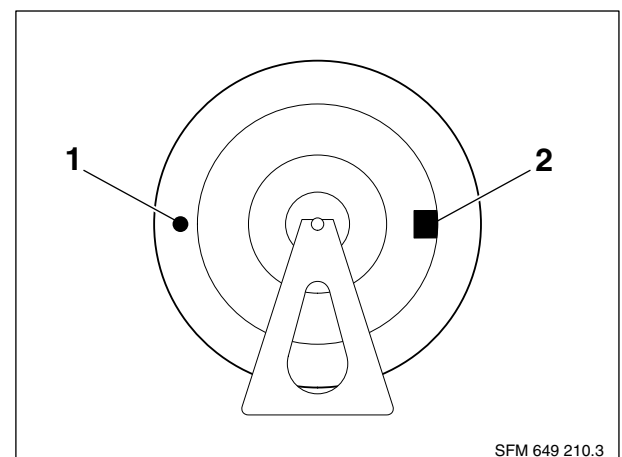
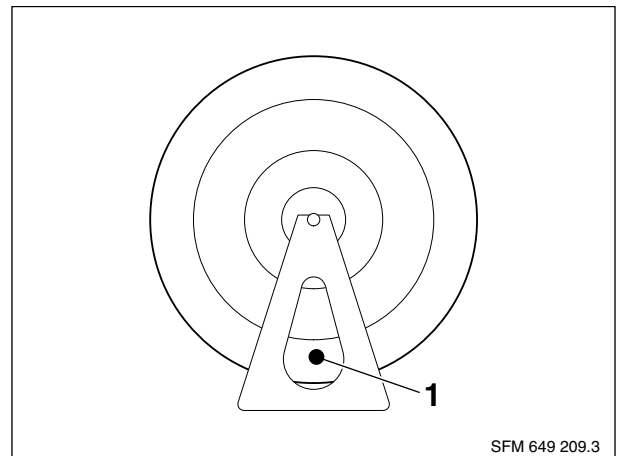

**LUBRICATION SYSTEM**

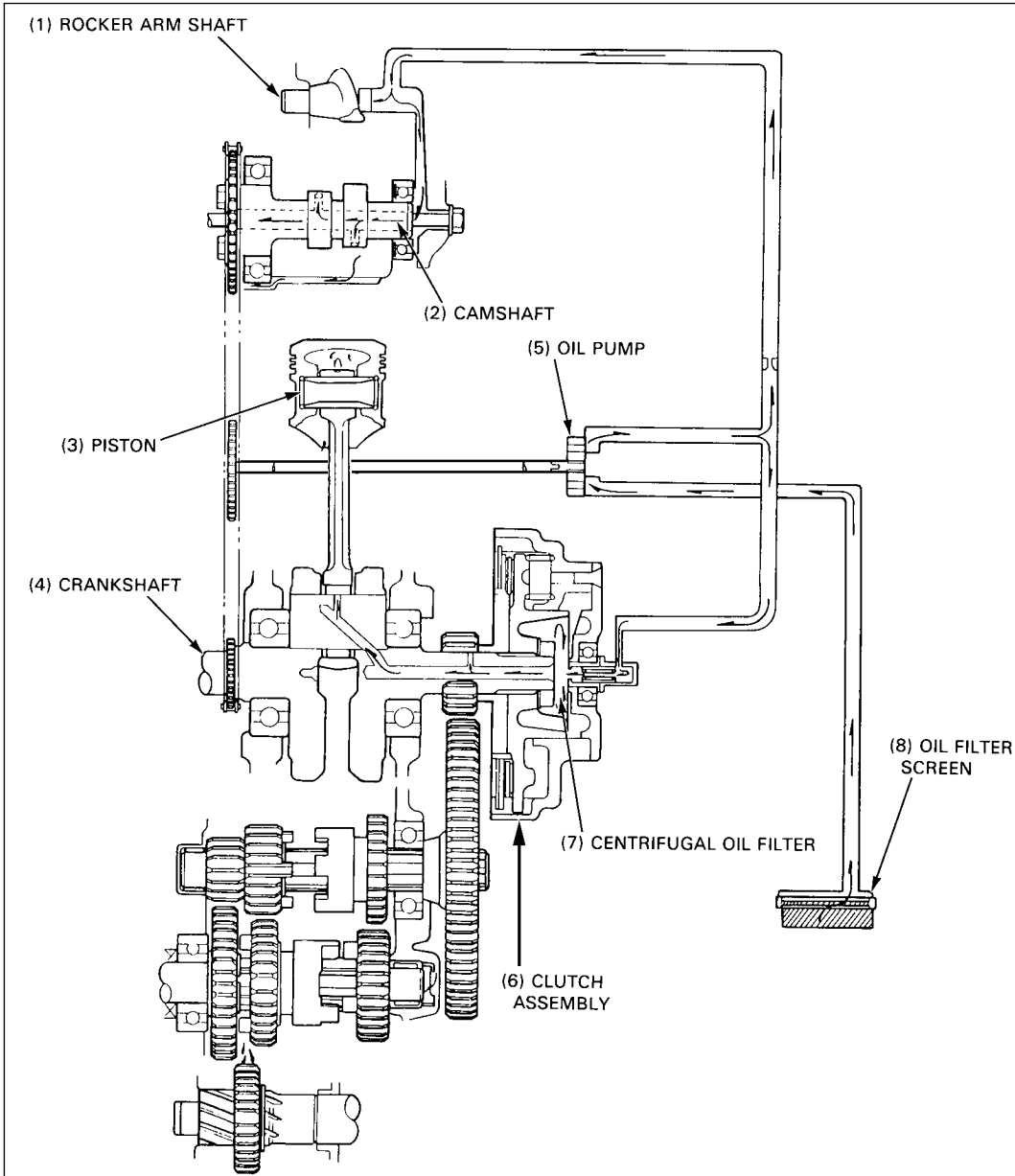

## LUBRICATION SYSTEM

### SERVICE INFORMATION

#### GENERAL

#### WARNING

If the engine must be running to do some work, make sure the area is well-ventilated. Never run the engine in an enclosed area. The exhaust contains poisonous carbon monoxide gas that may cause loss of consciousness and lead to death.

#### CAUTION

Used motor oil may cause skin cancer if repeatedly left in contact with the skin for prolonged periods. Although this is unlikely unless you handle used oil on a daily basis, it is still advisable to thoroughly wash your hands with soap and water as soon as possible after handling used oil.

- The oil filter screen and oil filter rotor cleaning and oil pump servicing can be done with the engine in the frame.
- Perform these maintenance procedures with the engine oil drained after removing the right crankcase cover.
- When cleaning the oil filter rotor, do not use compressed air.

#### SPECIFICATION

Engine oil capacity      1.0 litres at disassembly  
    0.8 litres at oil change

#### Engine oil:

Recommended grade:

Per API: SG or higher or also with additional release status: ACEAA3/96 (CCMC G5).

Recommended viscosity:

Viscosity depends on the outside temperature. For short while, the temperature may exceed or fall short of the limits of the SAE grades.

The recommended viscosity grade SAE 10W/40 covers the ambient temperature range -10 °C to +40 °C and therefore represents the optimum for our latitudes.

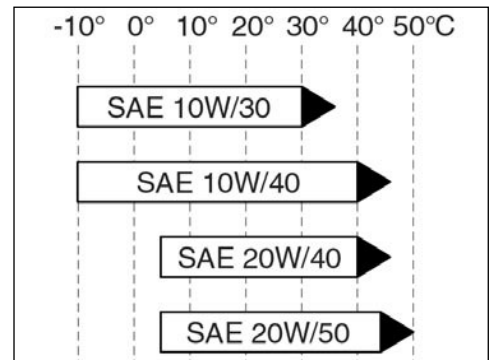

#### SERVICE DATA

Unit: mm (in)

ITEM		STANDARD	SERVICE LIMIT
Oil pump	Rotor tip clearance	0.15 (0.006)	0.20 (0.008)
	Rotor-to-body clearance	0.03-0.08 (0.001-0.003)	0.12 (0.005)
	Pump end clearance	0.10-0.21 (0.004-0.008)	0.27 (0.011)

#### TORQUE VALUES

Oil drain bolt    25 Nm

#### TROUBLESHOOTING

##### Oil level too low

- External oil leak
- Worn valve guide or oil seal
- Worn piston ring
- High oil consumption

##### Oil contamination

- Oil not changed often
- Blown cylinder head gasket

##### Low oil pressure

- Oil level too low
- Plugged oil filter, screen, oil passage or orifice
- Faulty oil pump
- Incorrect oil used
- Damaged oil pump drive sprocket (cam chain guide sprocket)
- Misaligned oil pump/cam chain guide sprocket

## LUBRICATION SYSTEM

### ENGINE OIL

#### OIL LEVEL CHECK

Support the motorcycle upright on level ground.  
Check the oil level with the filler cap/ dipstick (1).

#### CAUTION

**For checking the oil level only insert the oil filler cap and don't screw in!  
Otherwise there will be a wrong measurement.**

If the level is below the lower level mark (4) on the dipstick, add the recommended oil to the upper level mark (3).

### OIL CHANGE

#### NOTE

Change the engine oil with the engine warm to ensure complete and rapid draining.  
Remove the oil filler cap/ dipstick.  
Place an oil drain pan under the engine, and remove the drain bolt (2) and drain the engine oil.  
Make sure that the sealing washer is in good condition and install the drain bolt.

#### TORQUE: 25 Nm

Fill the crankcase with the recommended oil.

#### CAPACITY: 0.8 litres at oil change

Install the oil filler cap/ dipstick. Start the engine and let it idle for 2-3 minutes.

#### WARNING

**If the engine must be running to do some work, make sure the area is well-ventilated. Never run the engine in an enclosed area. The exhaust contains poisonous carbon monoxide gas that may cause loss of consciousness and lead to death.**

Stop the engine and check that the oil level is at the upper level mark on the dipstick with the motorcycle upright. Make sure there are no oil leaks.

### ENGINE OIL FILTER CLEANING

#### NOTE

Drain the engine oil before cleaning the filter.

Remove the right crankcase cover (1).  
Remove the clutch outer cover (2).  
Clean the clutch outer cover and inside of the clutch outer using a clean lint-free cloth.

#### NOTE

Do not allow dust and or dirt to enter the crankshaft oil passage.  
Do not use compressed air.

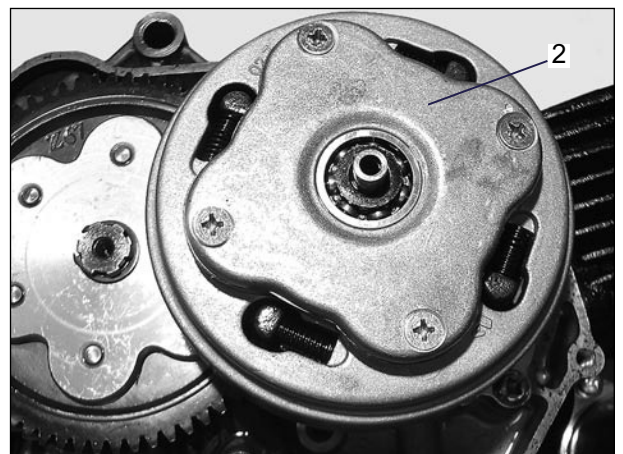
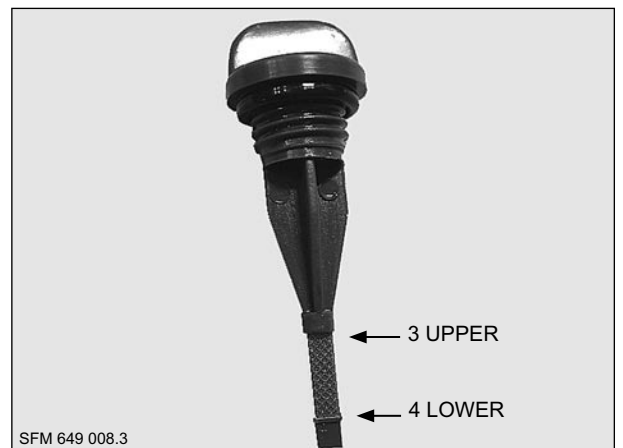
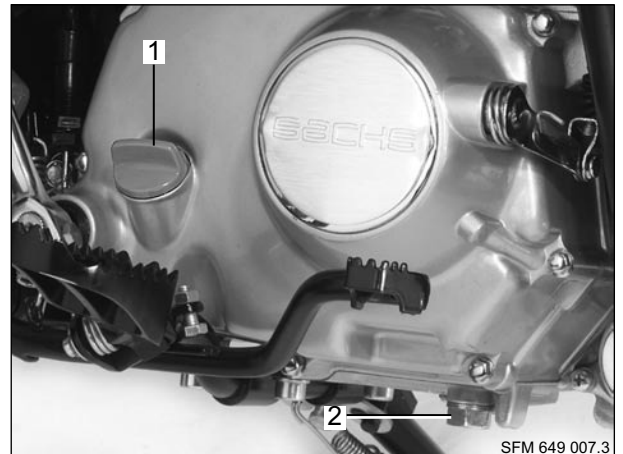

**LUBRICATION SYSTEM**

Install a new gasket and the clutch outer cover.

Remove the oil filter screen (1).

Clean the oil filter screen with solvent and blow it dry with compressed air.

Reinstall the oil filter screen into the right crankcase.

Install the removed parts in the reverse order of removal.

Fill the engine with recommended oil.

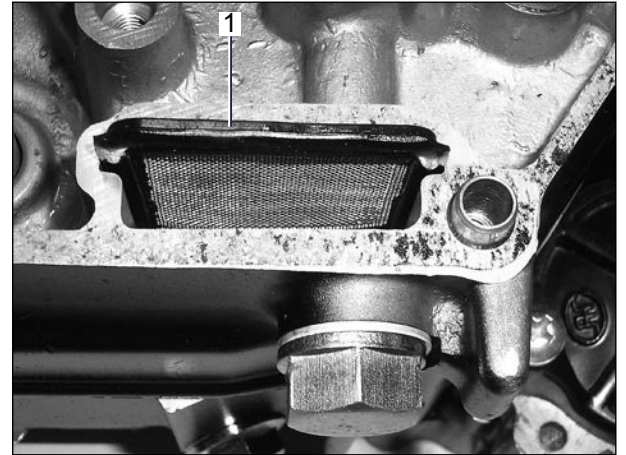

**OIL PUMP REMOVAL**

**NOTE**

The oil pump can be removed with the engine in the frame.

Drain the engine oil and remove the right crankcase cover.

Remove the clutch assembly.

Remove the three mounting screws (1), the oil pump (2), and the pump gasket (3).

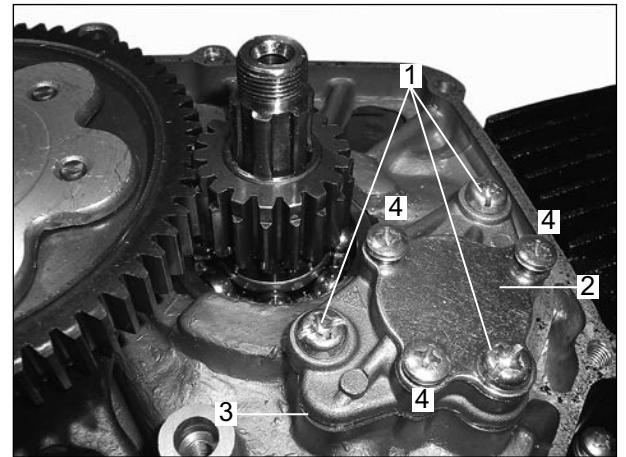

**DISASSEMBLY**

Remove the three cover screws (4), cover and gasket.

Remove the rotor shaft (5), inner rotor (6) and outer rotor (7).

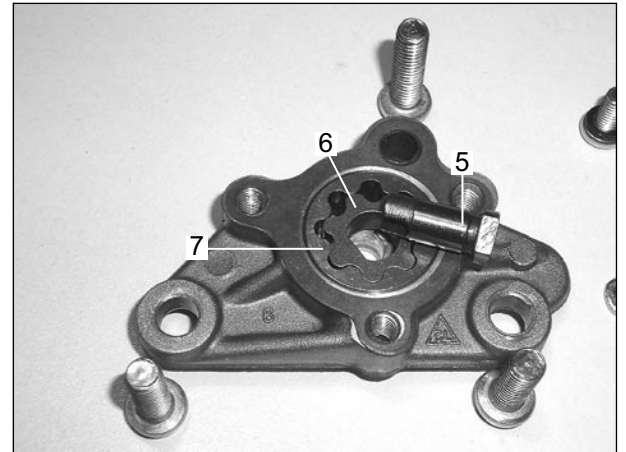

**LUBRICATION SYSTEM**

Clean all disassembled parts in solvent and check for damage or abnormal wear.

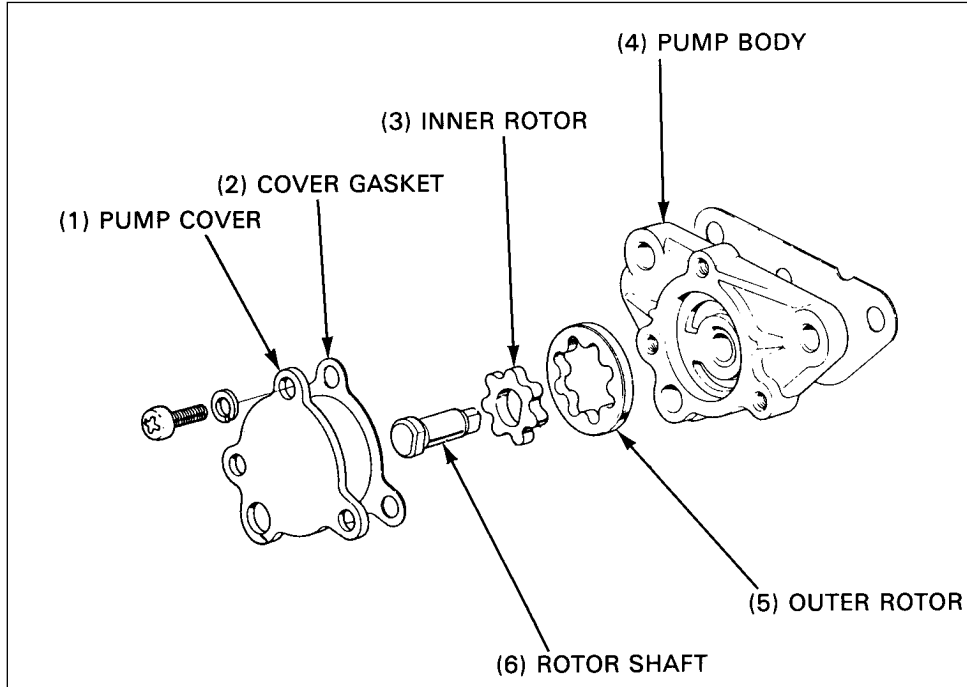
**INSPECTION**

Install the rotor shaft and inner and outer rotors into the pump body.

Measure the rotor tip clearance.

**SERVICE LIMIT: 0.20 mm (0.008 in)**

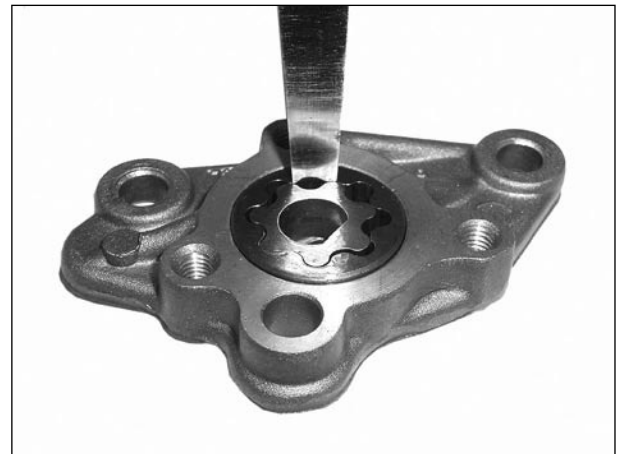

Measure the pump body clearance.

**SERVICE LIMIT: 0.12 mm (0.005 in)**



**LUBRICATION SYSTEM**

Install the pump cover gasket (1) and measure the pump end clearance.

**SERVICE LIMIT: 0.27 mm (0.011 in)**

**ASSEMBLY**

Install the outer rotor (2) and inner rotor (3).

Install the pump shaft (4) by aligning the flat (A) on the shaft with the flat (B) on the inner rotor.

Install a new cover gasket (5) and the pump cover (6).

Secure the cover with the three screws (7) and make sure that the oil pump turns freely without binding.

**INSTALLATION**

Set the shaft collar (1) into the right crankcase.  
Install a new oil pump gasket (2) and set the oil pump (3) onto the right crankcase by aligning the groove of the rotor shaft (4) with the cam chain guide spindle (5).

Tighten the oil pump mounting screws securely. Check the cover screws for looseness, retighten them if necessary.

Install the clutch assembly.

Install the removed parts in the reverse order of removal. Fill the engine with recommended oil.

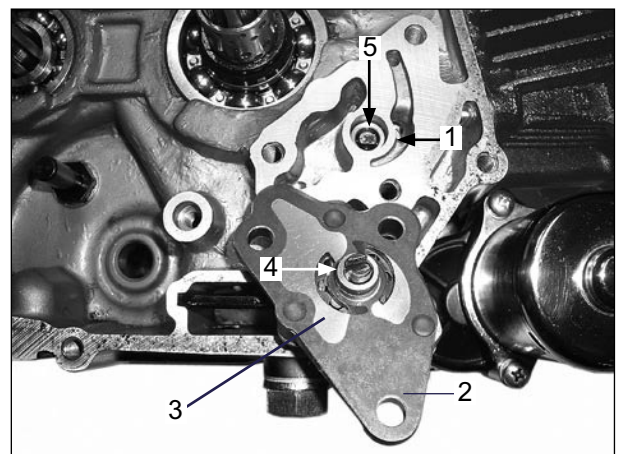
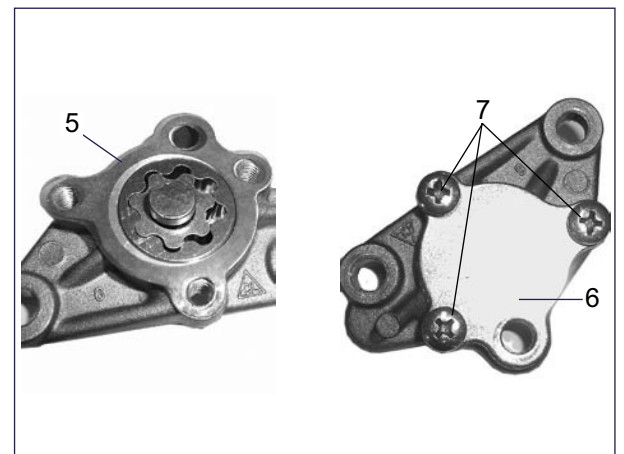
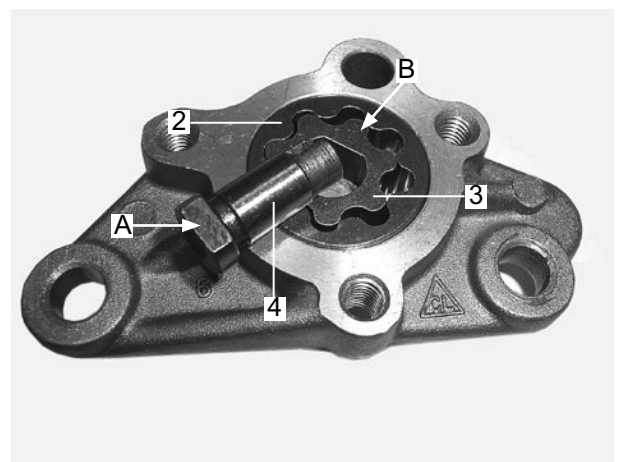
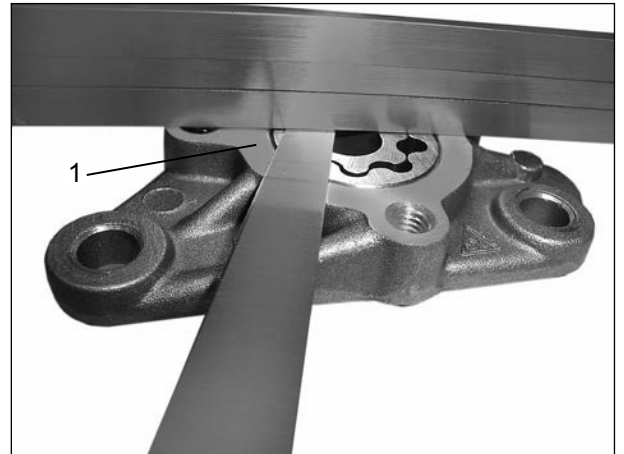



## FUEL SYSTEM

### SERVICE INFORMATION

#### GENERAL

##### WARNING

Gasoline is extremely flammable and is explosive under certain conditions. Work in a well ventilated area. Do not smoke or allow flames or sparks in the work area or where gasoline is stored.

If the engine must be running to do some work, make sure the area is well-ventilated.

Never run the engine in an enclosed area. The exhaust contains poisonous carbon monoxide gas that may cause loss of consciousness and lead to death.

##### CAUTION

Do not bend or twist the control cables. Damaged control cables will not operate smoothly and may stick or bind.

When disassembling the fuel System parts, note the locations of the O-rings. Replace them with new ones on reassembly. Before disassembling the carburetor, drain the fuel in the float chamber by loosening the drain screw.

##### NOTE

If vehicle is to be stored for more than one month, drain the float bowls. Fuel left in the float bowls will cause clogged jets resulting in starting and driveability complaints.

#### SPECIFICATIONS

Fuel tank capacity	4.6 lit
Fuel reserve capacity	0.35 lit
Throttle grip free play	2-6 mm

#### TROUBLESHOOTING

##### Engine cranks but won't start

- No fuel in tank
- No fuel to carburetor
- Engine flooded with fuel
- Clogged air cleaner
- No spark at plug

##### Engine idles roughly or runs poorly

- Incorrect idle speed
- Rich mixture
- Lean mixture
- Clogged air cleaner
- Intake air leak
- Fuel contaminated

##### Lean mixture

- Clogged carburetor jets
- Blocked fuel tank breather hole
- Clogged fuel strainer screen
- Restricted fuel line
- Faulty float valve
- Float level low

##### Rich mixture

- Choke stuck closed
- Faulty float valve
- Float level too high
- Clogged air jets

#### Carburetor Specification

Identification number	FYZ22PA-S3P
Venturi diameter	22 mm
Float level	18+/-0.5mm
Air screw opening	1.75~2 turns out
Idle speed	1500+/-100rpm
Main jet	#94
Main air jet	#40
Jet needle	2.595
Needle jet	5D07
Jet needle setting groove	3 rd from top

**FUEL SYSTEM**

**THROTTLE VALVE**

**REMOVAL**

Unscrew the carburetor (1) top and pull out the throttle valve (2).

Compress the valve spring as shown and disconnect the throttle cable end (1) from the throttle valve through the groove while compressing the throttle valve spring as shown.

Remove the throttle valve (2), spring (3) and carburetor top.

Remove the needle retainer and take out the jet needle from the throttle valve.

Check the throttle valve and jet needle for scratches or wear.

**ASSEMBLY**

Install the needle clip into the jet needle groove.

**STANDARD SETTING:** 3<sup>rd</sup> GROOVE FROM TOP

Install the jet needle in the throttle valve.

Install the jet needle retainer.

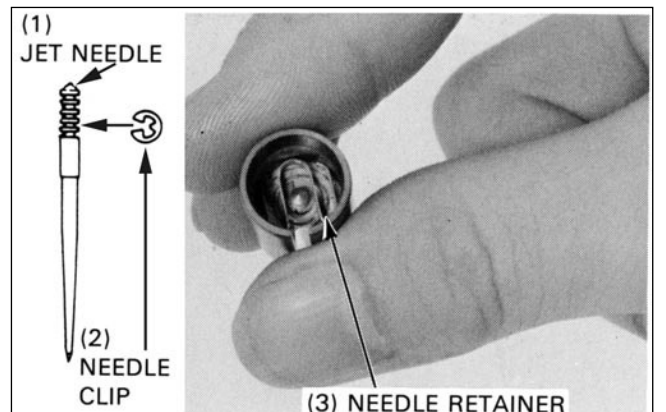
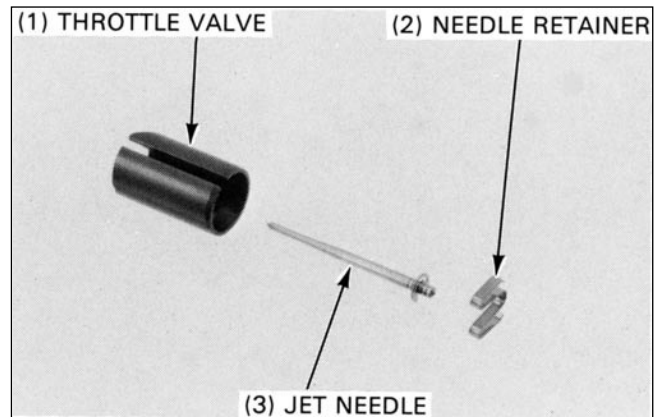
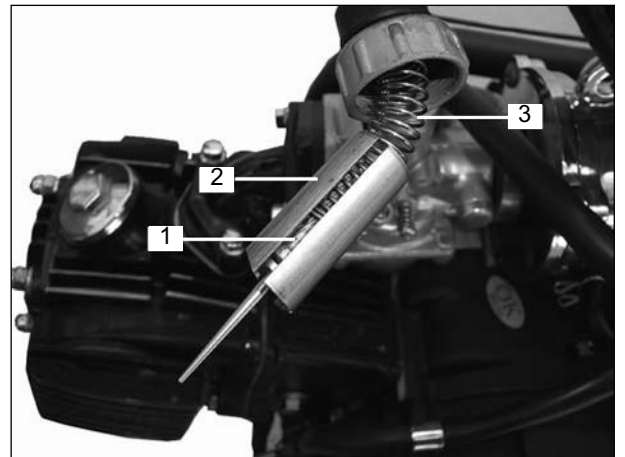
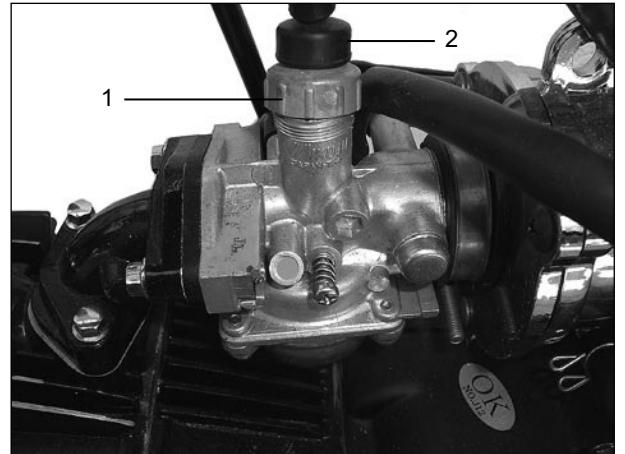

**FUEL SYSTEM**

Route the throttle cable end through the carburetor top.

Install the throttle valve spring.

Connect the throttle cable to the throttle valve.

Install the throttle valve in the carburetor by aligning the throttle valve groove with the throttle stop screw.

Perform the following adjustments:

- Throttle grip free play
- Carburetor idle speed

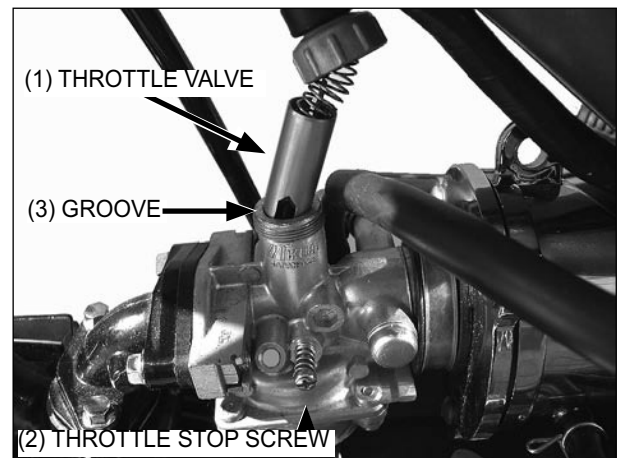
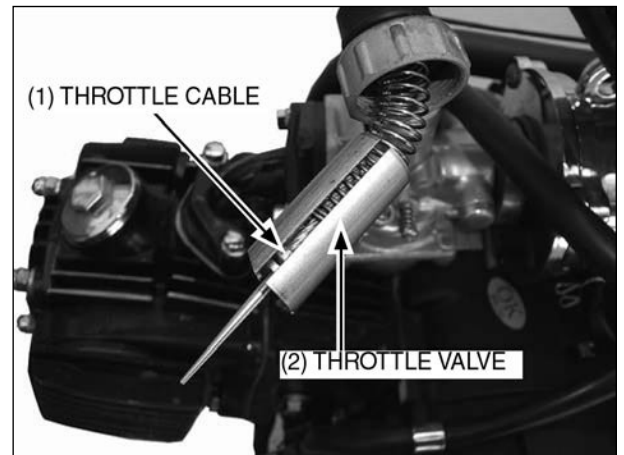

**CARBURETOR REMOVAL**

**WARNING**

Gasoline is extremely flammable and is explosive under certain conditions. Work in a well ventilated area. Do not smoke or allow flames or sparks in the work area or where gasoline is stored.

Wipe up spilled gasoline at once.

Turn the fuel petcock OFF and remove the hose.

Remove the carburetor top and throttle valve.

Loosen the drain screw to drain the fuel from the carburetor.

Loosen the air cleaner connecting tube band.

Remove the carburetor mounting bolts and carburetor.

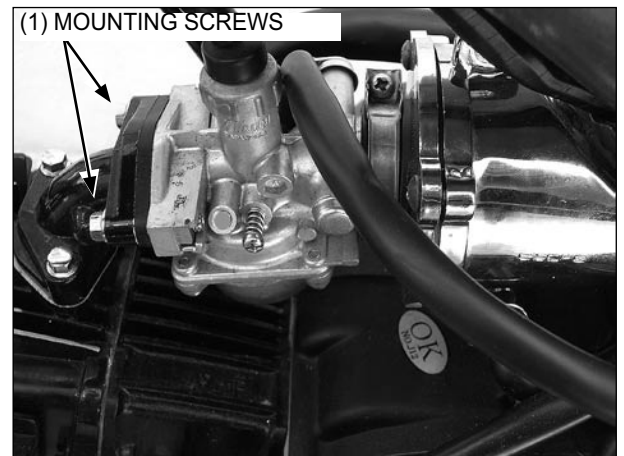

**DISASSEMBLY**

Remove the air vent and drain tubes.

Remove the float chamber by removing four screws (2).

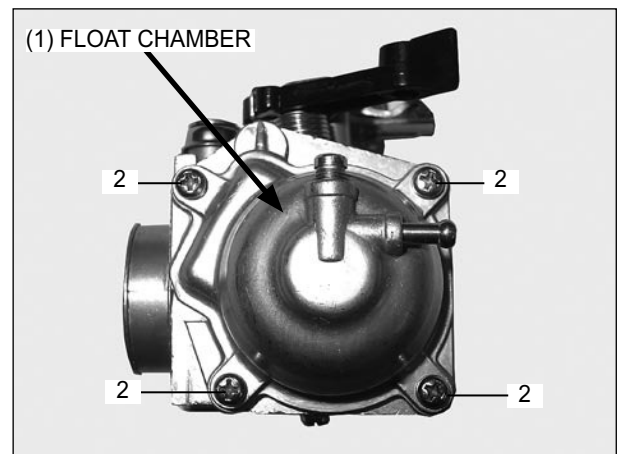

**FUEL SYSTEM**

Pull out the float arm pin (1) and remove the float (2) and float valve (3).

**FLOAT VALVE/FLOAT INSPECTION**

Inspect seating surface of the float valve (3) for wear or damage.

Inspect the float valve for grooves and nicks, and replace if necessary.

Check the Operation of the float valve.

Check the float for damage and fuel in float.

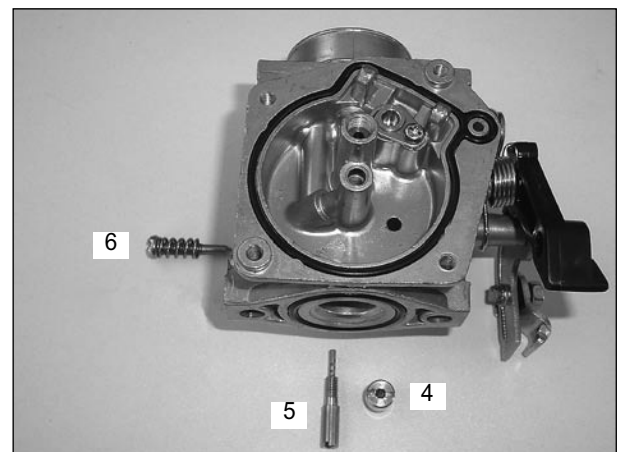
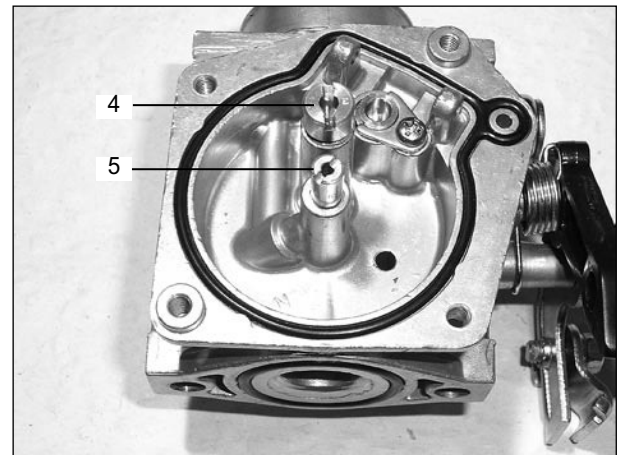
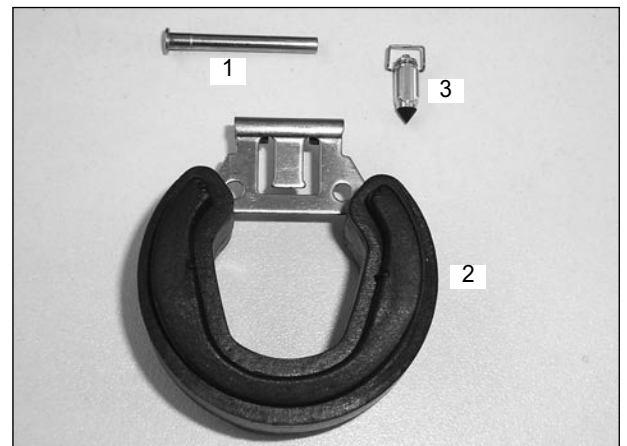
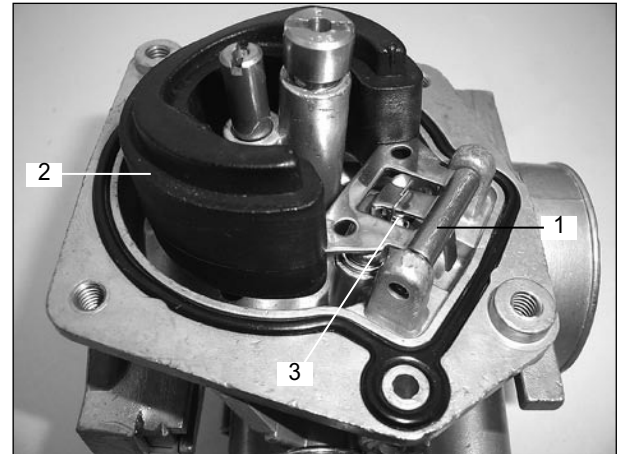

Remove the main jet (4).

Remove the pilot jet (5).

Remove the throttle stop screw (6).

Clean all disassembled parts with solvent and dry them.

Inspect each jet and replace them if they are worn or damaged.

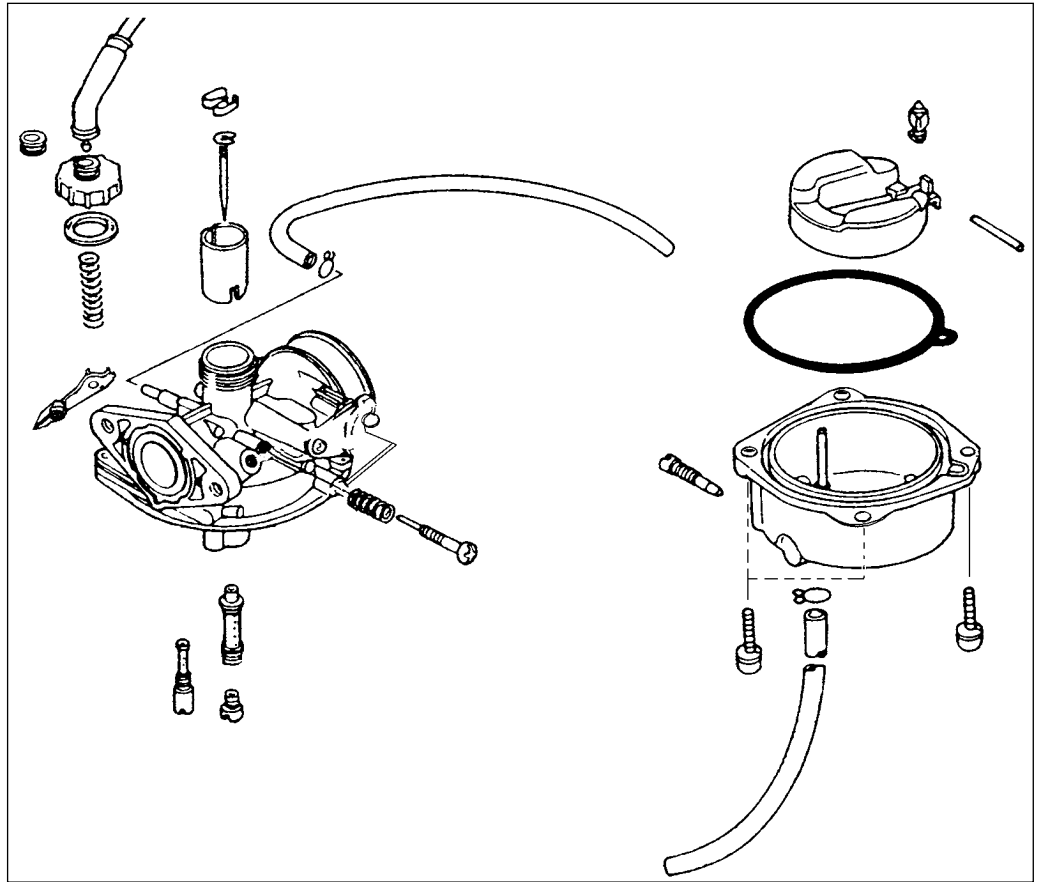
**FUEL SYSTEM****ASSEMBLY**

Clear all Jets and carburetor openings with compressed air.

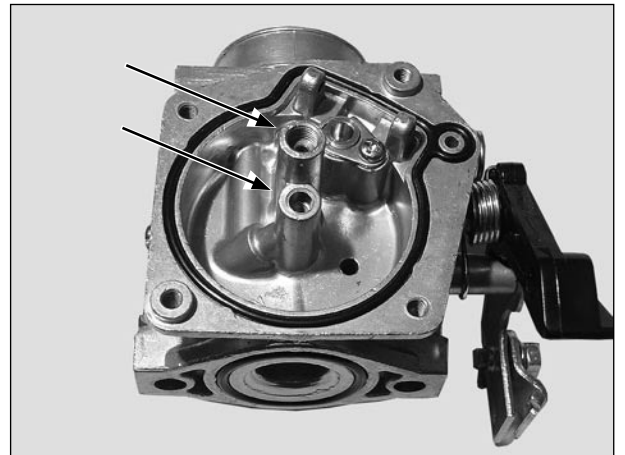

Install the needle jet (1) and main jet (2).

Install the throttle stop screw (3).

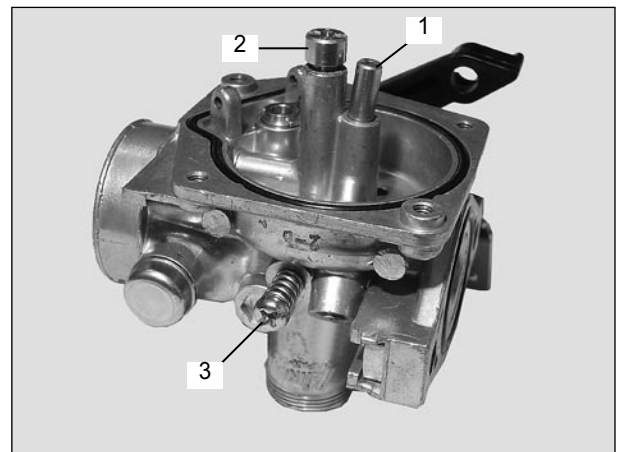

**FUEL SYSTEM**

Install the float valve (1), float (2) , and float arm pin (3).

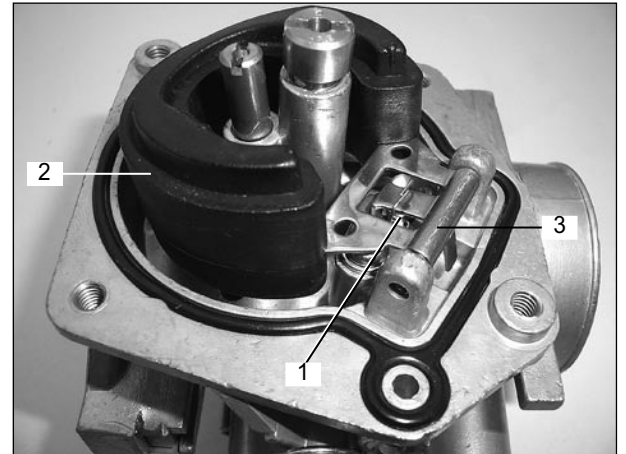
**FLOAT LEVEL INSPECTION**

Measure the float level with the carburetor inclined 15—45° from vertical so that the float tang just contacts the float valve.

**FLOAT LEVEL: 18.0 mm**

TOOL: VERNIER CALLIPER

Make sure the float moves smoothly.

Install a new O-ring (4) in the carburetor groove.

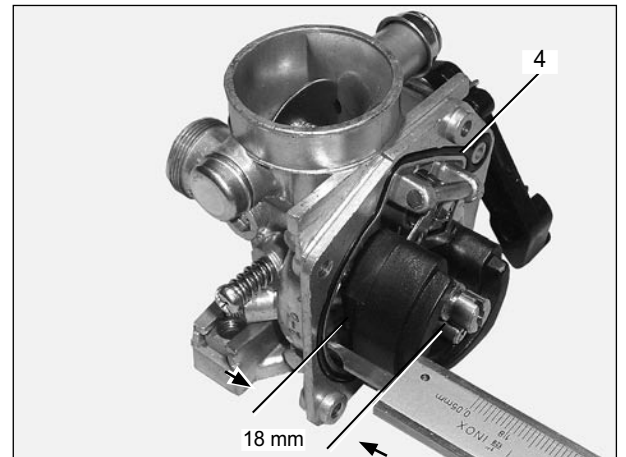

Install the float chamber (5) and tighten the screws (6).

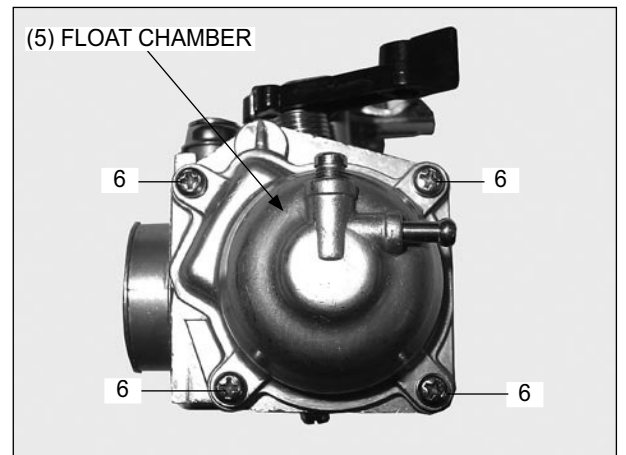

## FUEL SYSTEM

### INSTALLATION

Install the carburetor in the reverse order of removal.

#### NOTE

Make sure that the O-rings on the intake pipe and insulator are installed properly.

Tighten the connecting tube band screw.

Install the air vent and drain tubes.

Install the throttle valve.

Warm up the engine to operating temperature.

#### WARNING

**If the engine must be running to do some work, make sure the area is well-ventilated, Never run the engine in an enclosed area. The exhaust contains poisonous carbon monoxide gas that may cause loss of consciousness and lead to death.**

Stop the engine and connect a tachometer.

Start the engine and adjust the idle speed with the throttle stop screw.

**IDLE SPEED:** 1,500+/-100rpm

Turn the air screw in or out to obtain the highest engine speed.

Readjust the idle speed to specified rpm with the throttle stop screw.

Make sure that the engine does not miss or run erratically.

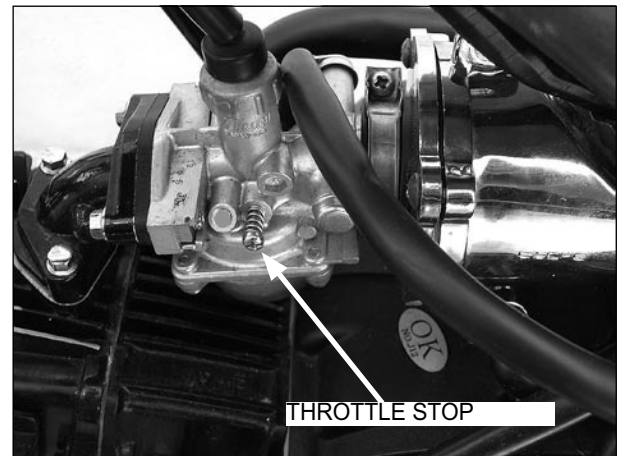

**FUEL SYSTEM**

**Removing/installing the fuel petcock**

**Removing the fuel petcock**

- Turn the fuel petcock on position RES.
- Open the seal and drain the fuel tank completely.
  
- Loosen the hose clamps (3) and pull off the fuel hose (4).
- Remove the fuel petcock.
- Clean the sleeve (5).

**Installing the fuel petcock**

**NOTE**

Check the sealing rings (6 and 7) and replace if necessary.

- Reassemble in reverse order.

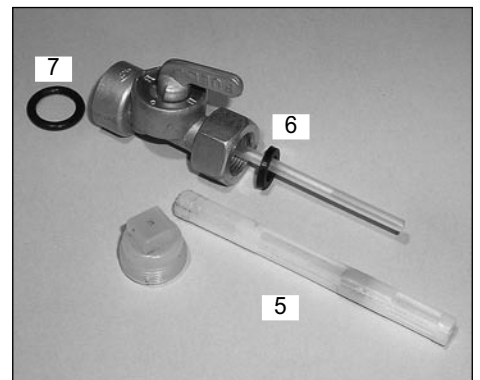
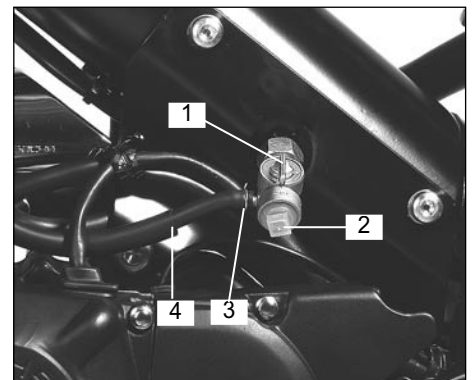
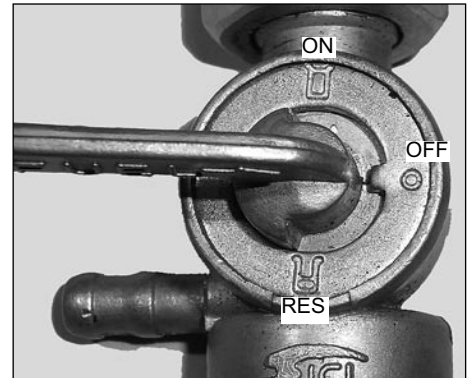



## ENGINE DISASSEMBLY/ASSEMBLY

### SERVICE INFORMATION

#### GENERAL

When removing the engine, support the motorcycle using safety stands.

Parts requiring engine removal for servicing:

Crankcase

Transmission

Shift drum and forks

Crankshaft

Kick starter spindle

SPECIFICATION	
Engine oil capacity	0.9 lit after draining
	1.0 lit after disassembly
Engine dry weight	23kg / 49 lbs
TORQUE VALUES	
Engine upper mounting bolt	33-35 Nm
Engine lower mounting bolt	33-35 Nm
Exhaust pipe joint nut	10-12 Nm
Intake manifold mounting bolt	10-12 Nm
Rear axle nut	50-60 Nm
Drive sprocket bolt	12-15 Nm

**CYLINDER HEAD / VALVES**

**SERVICE INFORMATION**

**GENERAL**

This section covers maintenance of the cylinder head, valves, camshaft and rocker arms.  
Camshaft lubrication oil is fed to the cylinder head through an oil control orifice in the engine case.  
Be sure this orifice is not clogged and that the O-ring and dowel pins are in place before installing the cylinder head.  
Apply clean engine oil to the camshaft bearings to provide initial lubrication.

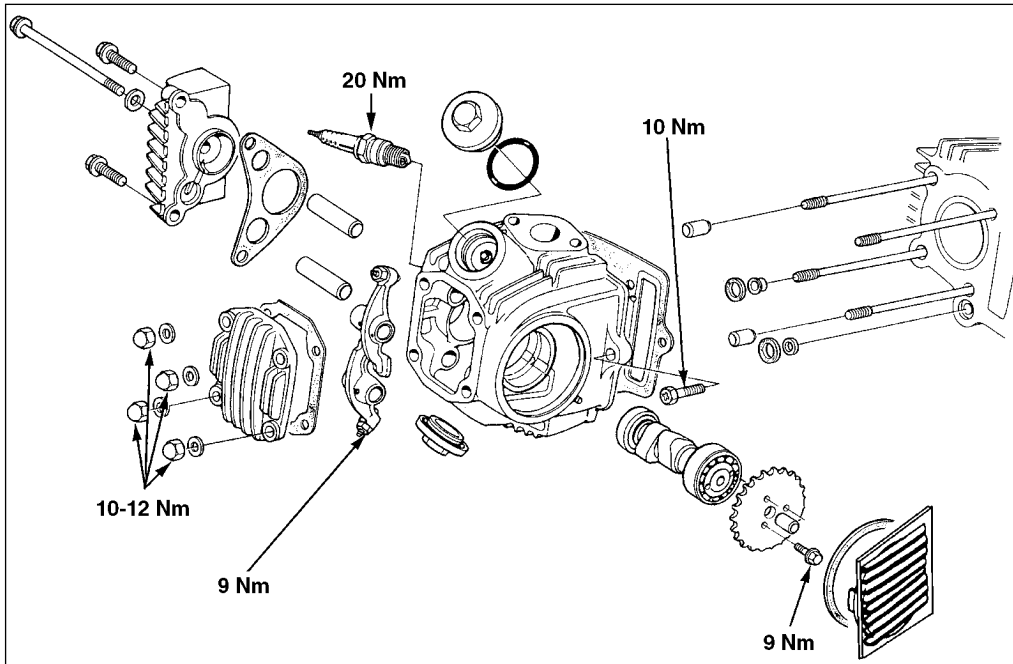

**SERVICE DATA**

Unit : mm

ITEM		STANDARD	SERVICE LIMIT
Cylinder head	Warpage	—	0.05
	Valve seat width	1.0	1.6
Cam height	IN	5.623	5.223
	EX	5.386	4.986
Rocker arm I.D.		10.000-10.015	10.10
Rocker arm shaft O.D.		9.972-9.987	9.91
Rocker arm-to-shaft clearance		0.013-0.037	0.05
Valve spring free length		IN: 33.78, EX:36.5	IN: 32, EX:35
Valve stem O.D.	IN	4.970-4.985	4.92
	EX	4.970-4.985	4.92
Valve guide I.D.	IN	5.000-5.012	5.03
	EX	5.000-5.012	5.03
Valve stem-to-guide clearance	IN	0.015-0.042	0.08
	EX	0.030-0.057	0.10

**TORQUE VALUES**

Cylinder head nut	10-12 Nm
Cylinder head bolt	10-12 Nm
Cam sprocket bolt	9 Nm
Cam chain tensioner sealing bolt	25 Nm

**CYLINDER HEAD / VALVES****TROUBLESHOOTING**

Engine top-end problems are usually performance-related and can be diagnosed by a compression test. Engine noises can usually be traced to the top-end with a sounding rod or stethoscope.

**Uneven compression or low compression**

- Valve troubles
  - Incorrect valve adjustment
  - Burnt or bent valves
  - Incorrect valve timing
  - Broken valve spring
  - Worn or damaged valve seat
- Cylinder head
  - Leaking or damaged head gasket
  - Warped or cracked cylinder head
- Faulty cylinder or piston

**High compression**

- Excessive carbon build-up on piston or combustion chamber

**Excessive noise**

- Incorrect valve adjustment
- Sticking valve or broken or weak valve spring
- Damaged or worn rocker arm or rocker arm shaft
- Damaged camshaft bearing

## CYLINDER HEAD / VALVES

### CAMSHAFT REMOVAL

Remove the spark plug (1).  
Loosen the 6 mm bolt (2) and tap it to lift the left side cover.

Remove the left side cover (3) and gasket (4).

Remove the left crankcase cover.

Remove the cam chain tensioner sealing bolt, spring and tensioner push rod.

Turn the flywheel counterclockwise until the "O" mark (5) on the cam sprocket aligns with cut-out (6) on the cylinder head.

Remove the cam sprocket bolts (7) and dowel pin (8).  
Remove the cam sprocket (9).

#### NOTE

Suspend the cam chain with a piece of wire (A) to prevent it from falling into the cylinder head.

Remove the valve adjuster covers and loosen the valve adjusters completely.

Screw the cam sprocket bolts into the camshaft and pull out the camshaft (1) while holding the rocker arms.

#### NOTE

Cylinder head can be removed with the camshaft installed on the cylinder head.

### INSPECTION

Turn the outer race of the camshaft bearing (2) with finger.

The outer race should turn smoothly and quietly.

Also check that the bearing inner race fits tightly on the camshaft.

Replace the camshaft bearing if the outer race does not turn smoothly, quietly, or if it fits loosely on the camshaft.

Check each cam lobe for wear or damage.

Measure the cam lobe height.

#### SERVICE LIMITS:

IN: 18.705 mm

EX: 18.697 mm

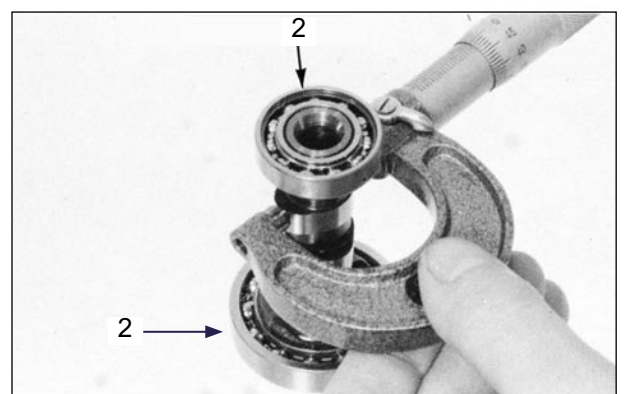
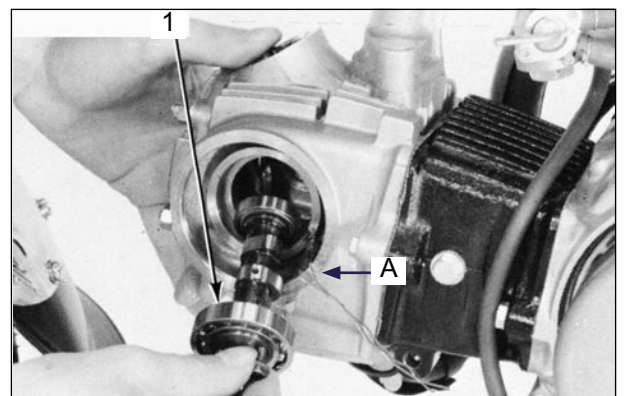
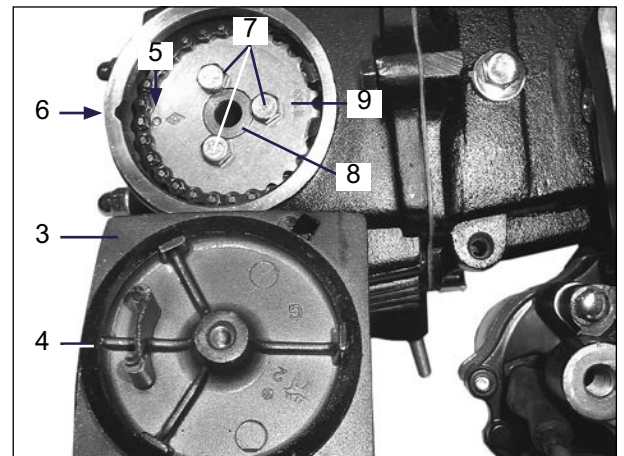
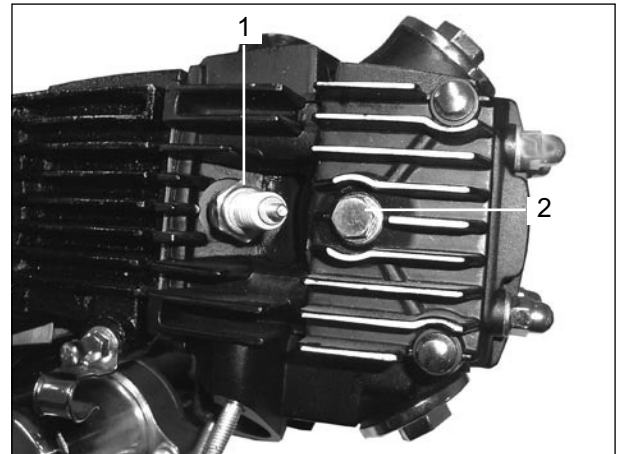

**CYLINDER HEAD / VALVES**

**CYLINDER HEAD REMOVAL**

Remove the muffler (1).

Remove the intake manifold bolts (2) from cylinder head.

Remove the following:

- cam sprocket
- cylinder head nuts and cylinder head bolt.
- cylinder head cover and gasket.
- cylinder head.

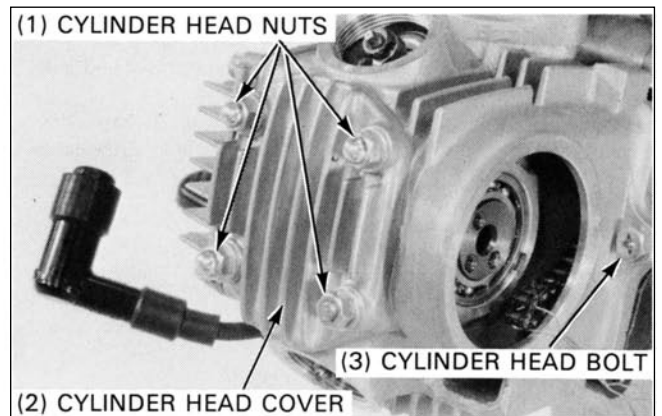

**CYLINDER HEAD DISASSEMBLY**

Remove the two bolts, right side cover and gasket.

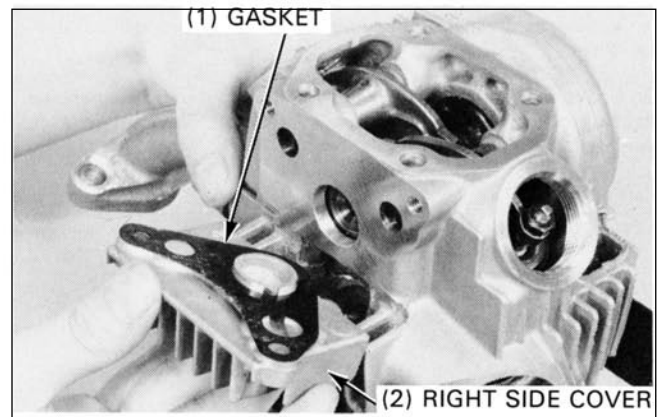

Screw an 8 mm bolt into the thread end of the rocker arm shaft and pull out the rocker arm shaft.

Remove the rocker arms.

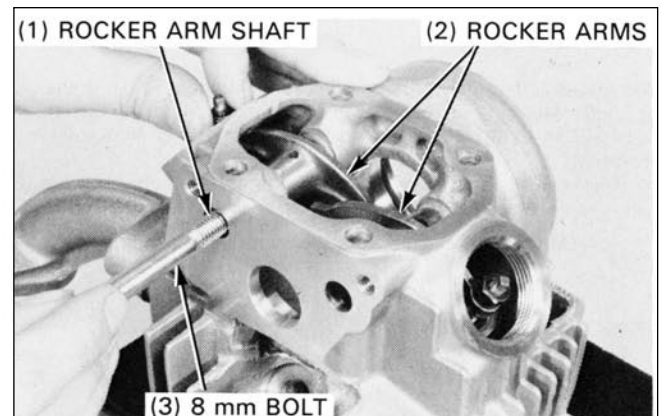

**CYLINDER HEAD / VALVES**

While compressing the valve spring with a valve spring compressor, remove the valve cotters.

**CAUTION**

To prevent loss of tension, do not compress the valve springs more than necessary to remove the cotters.

**TOOLS:**

Commercially available tools.

Loosen the valve spring compressor and remove the valve retainer, valve spring, spring seat and valve.

**NOTE**

Mark all disassembled parts to ensure correct reassembly.

Remove the stem seals, if necessary.

**NOTE**

Replace the stem seals with new ones whenever they are removed.

Remove the carbon deposits from the combustion chamber. Clean off any gasket material from the cylinder head surface.

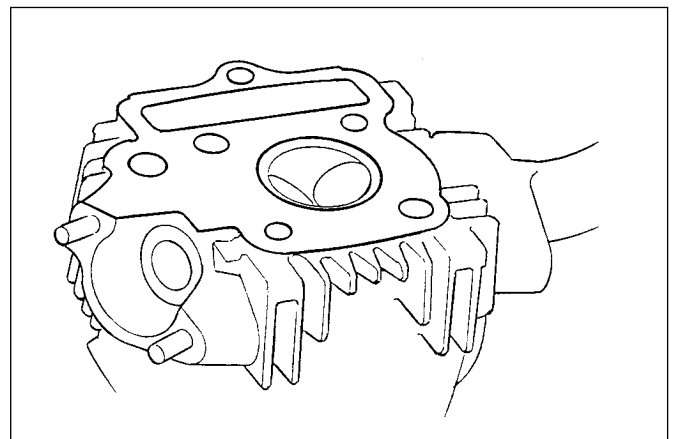
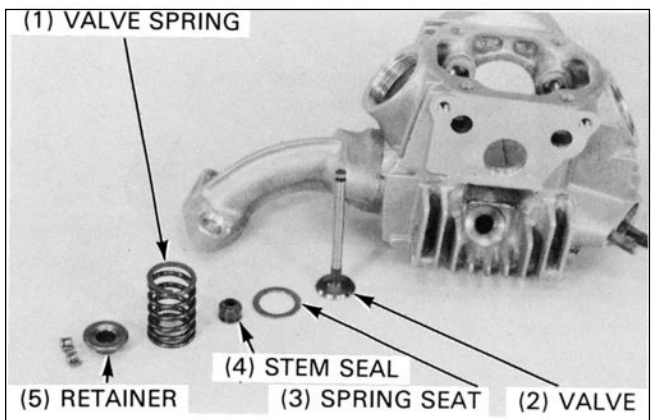
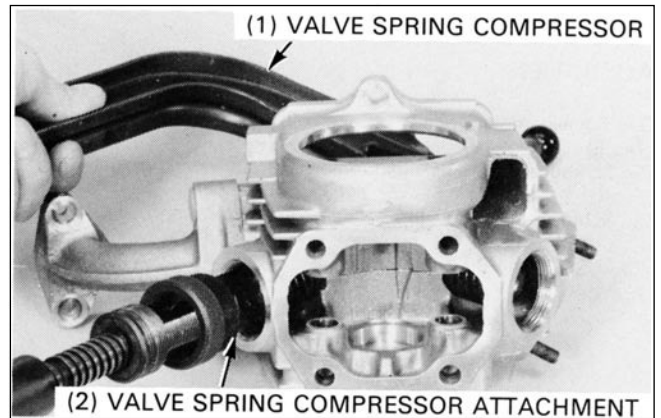

**INSPECTION**

**Rocker arm**

Inspect the rocker arm for wear, damage or clogged oil holes.

**NOTE**

If any rocker arm requires servicing or replacement, inspect the cam lobes for scoring, chipping or excessive wear.

Measure the rocker arm I.D.

**SERVICE LIMIT: 10.10 mm**

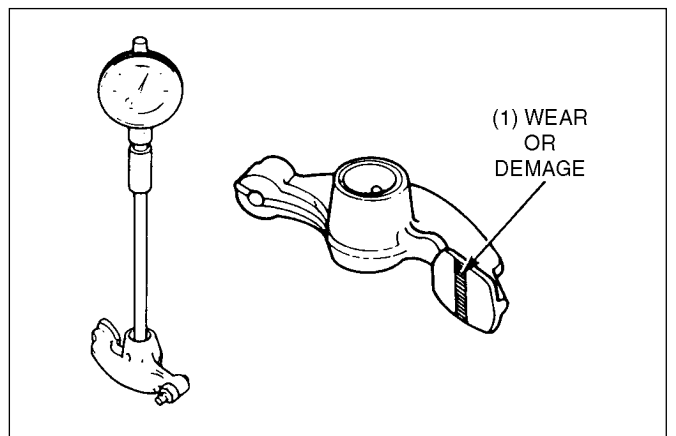

**CYLINDER HEAD / VALVES****Rocker Arm Shaft**

Inspect the rocker arm shaft for wear or damage.

Measure the rocker arm shaft O.D.

**SERVICE LIMIT: 9.91 mm**

Calculate the rocker arm-to-shaft clearance.

**SERVICE LIMIT: 0.05 mm**

**Valve Spring**

Measure the free length of the valve spring.

**SERVICE LIMIT: 32 mm**

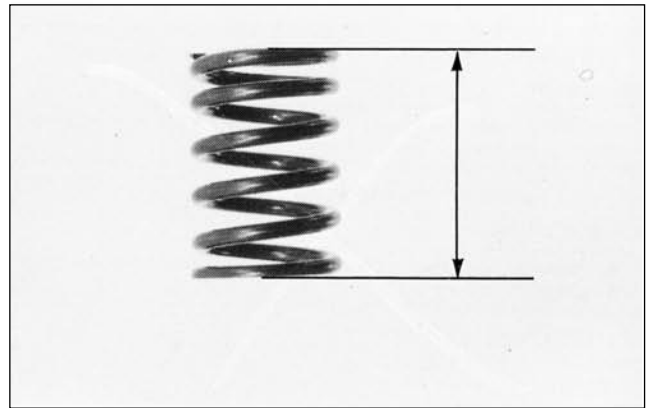
**Cylinder Head**

Check the spark plug hole and valve area for cracks.  
Check the cylinder head for warping with a straight edge and a feeler gauge.

**SERVICE LIMIT: 0.05 mm**

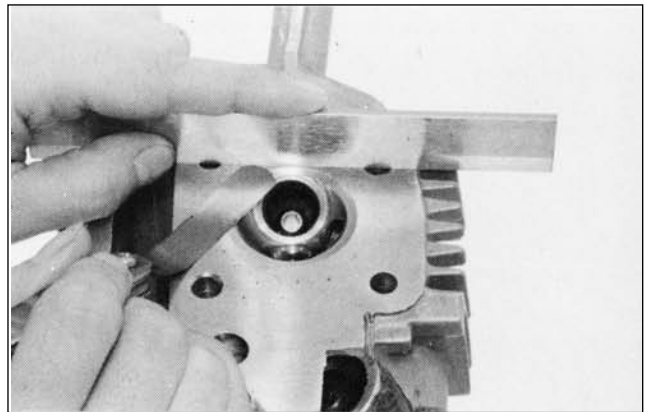
**Valve**

Inspect each valve for trueness, burning, scratches or abnormal stem wear.

Measure the valve stem O.D.

**SERVICE LIMIT:**

**IN/EX: 4.92 mm**

Insert each valve into the valve guide and check the valve movement in the guide.



## CYLINDER HEAD / VALVES

### Valve guide

#### NOTE

Ream the valve guide to remove the carbon build-up before checking the valve guide.

Always rotate the reamer clockwise, never counterclockwise when installing, removing and reaming.

Measure and record each valve guide I.D. with a ball gauge or inside micrometer.

#### SERVICE LIMIT:

**IN/EX: 5.03 mm**

Calculate the stem-to-guide clearance.

#### SERVICE LIMIT:

**IN 0.08 mm**

**EX: 0.10 mm**

#### NOTE

If the stem-to-guide clearance exceeds the Service limit, determine if a new guide with Standard dimensions would bring the clearance within tolerance. If so, replace the guides as necessary and ream to fit.

If the stem-to-guide clearance still exceeds the service limit with new guides, replace the valves and guides.

Reface the valve seat whenever new valve guides are installed.

### VALVE GUIDE REPLACEMENT

Chill the valve guides in the freezer section of a refrigerator for about an hour.

Heat the cylinder head to 100°C with a hot plate or oven.

#### WARNING

**To avoid burns, wear heavy gloves when handling the heated cylinder head.**

#### CAUTION

Do not use a torch to heat the cylinder head; the use of a heat torch may cause warping.

Support the cylinder head and drive out the valve guide from the valve port with a valve guide driver.

#### CAUTION

**Avoid damaging the cylinder head.**

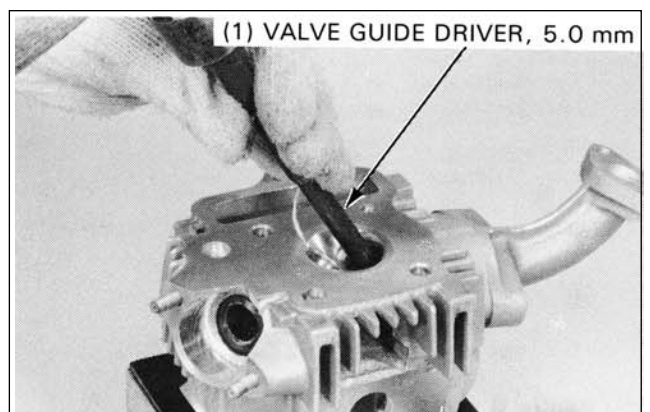
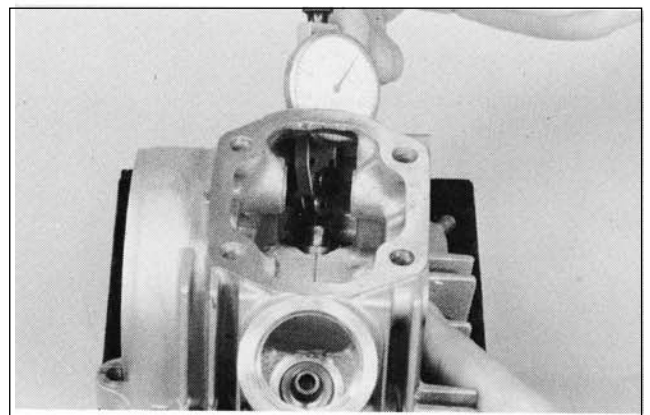
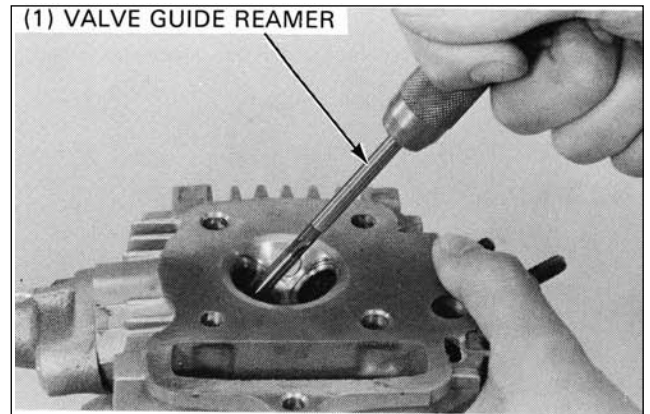



**CYLINDER HEAD / VALVES**

Install a new valve guide (oversize) from the top of the cylinder head.

**CAUTION**

When installing a valve guide take care not to damage the cylinder head.

After driving in the valve guide, ream it with a valve guide reamer.

**NOTE**

Use cutting oil on the reamer during this Operation.  
Always rotate the reamer clockwise, never counterclockwise.

Clean the cylinder head thoroughly to remove any metal particles.

Reface the valve seat.

**VALVE SEAT INSPECTION/REFACING**

**VALVE SEAT INSPECTION**

Clean the intake and exhaust valves thoroughly to remove carbon deposits.

Apply a light coating of Prussian Blue to the valve seats. Lap the valves and seats using a rubber hose or other handlapping tool. Remove the tool and inspect the width of each valve seat.

**STANDARD:** 1.0 mm  
**SERVICE LIMIT:** 1.6 mm

If the valve seat is too wide, too narrow or has low spots, the seat must be ground.

**CAUTION**

The valve cannot be ground. If a valve face is burned or badly worn or it contacts the seat unevenly, replace the valve.

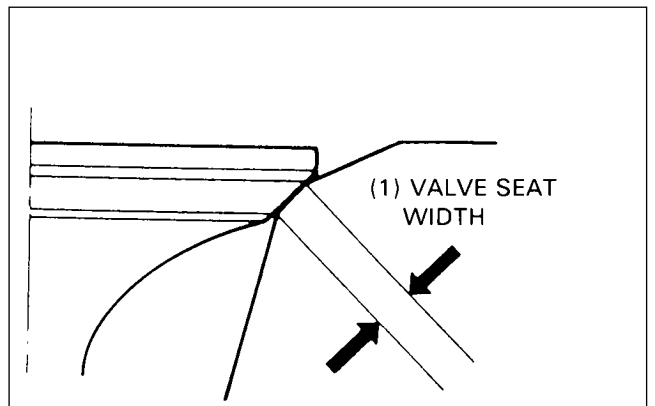
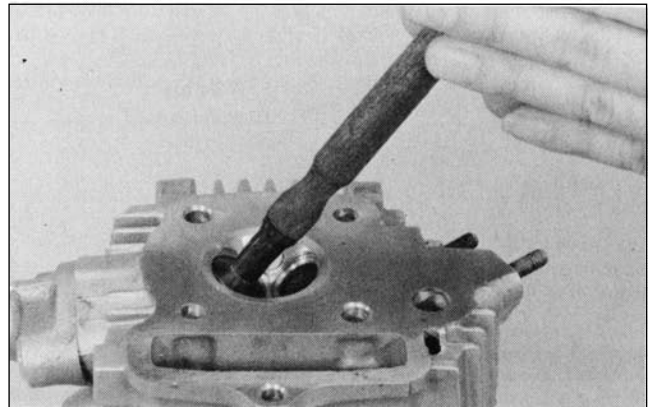
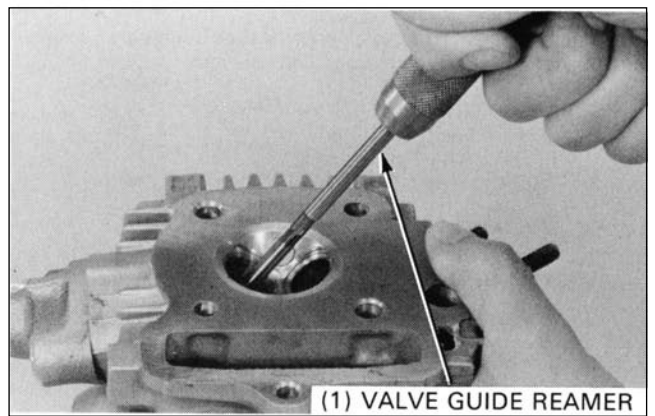
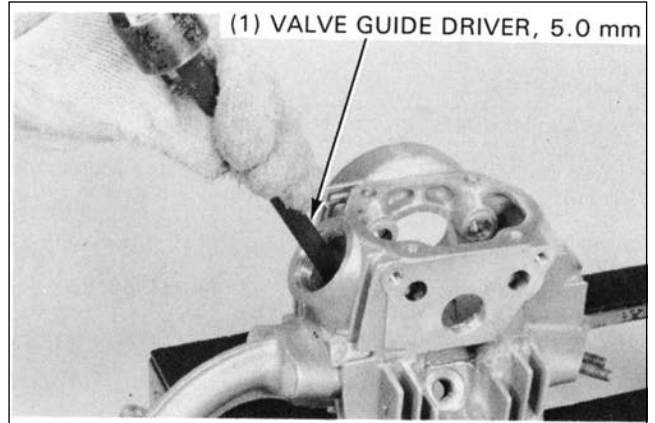

**CYLINDER HEAD / VALVES**

**VALVE SEAT GRINDING**

Valve Seat Cutters, a grinder or equivalent valve seat refacing equipment are recommended to correct a worn valve seat.

**NOTE**

Follow the refacer manufacturers operating instructions.

Use a 45 degree cutter to remove any roughness or irregularities from the seat.

**NOTE**

Reface the valve seat with a 45 degree cutter when a valve guide is replaced.

Using 32 degree cutter, remove 1 / 4 of the existing valve seat material.

Using 60 degree cutter, remove the bottom 1/4 of the old seat. Remove the cutter and inspect the area you have just removed.

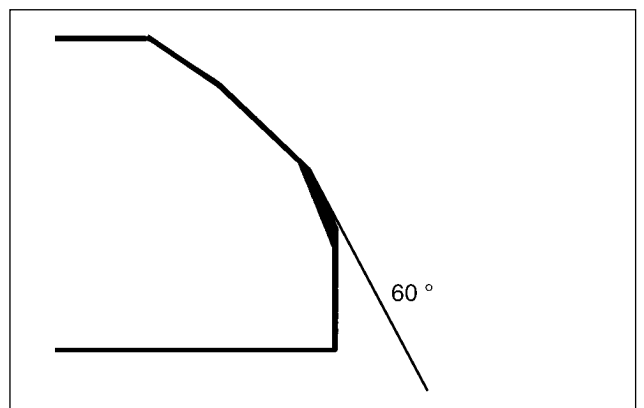
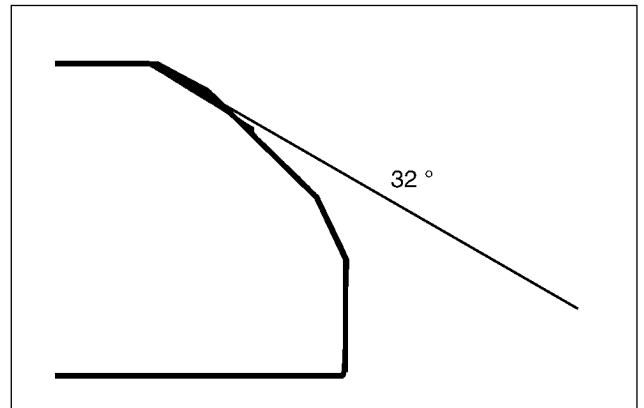
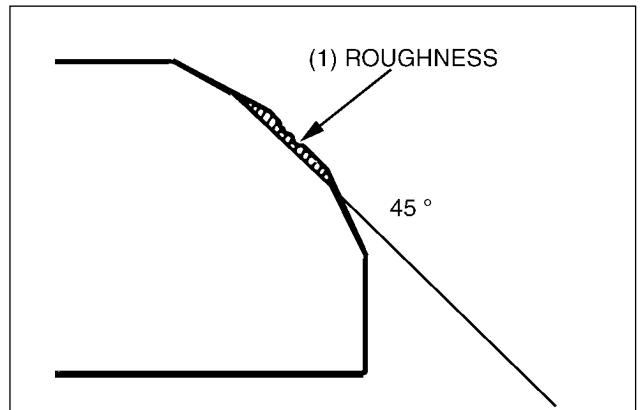
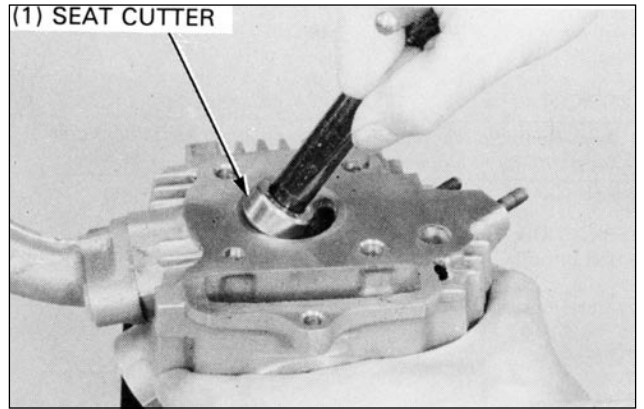

**CYLINDER HEAD / VALVES**

Install a 45 degree finish cutter and cut the seat to proper width. Make sure that all pitting and irregularities are removed. Refinish if necessary.

**STANDARD SEAT WIDTH: 1.0 mm**

Apply a thin coating of Prussian Blue to the valve seat. Press the valve through the valve guide and onto the seat to make a clear pattern.

**NOTE**

The location of the valve seat in relation to the valve face is very important for good sealing.

If the contact area is too high on the valve, the seat must be lowered using a 32 degree flat cutter.

If the contact area is too low on the valve, the seat must be raised using a 60 degree inner cutter.

Refinish the seat to specifications, using a 45 degree finish cutter.

After cutting the seat, apply lapping compound to the valve face, and lap the valve using light pressure.

After lapping, wash all residual compound off the cylinder head and valves.

**CYLINDER HEAD ASSEMBLY**

Install new valve stem seals.  
Lubricate each valve stem with the engine oil.  
Insert the intake and exhaust valve into the valve guides.

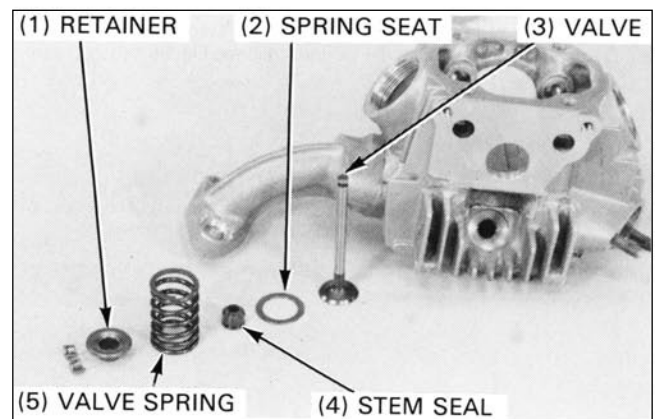
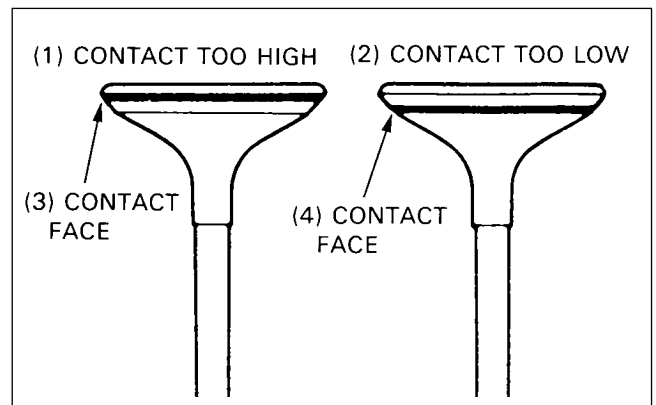
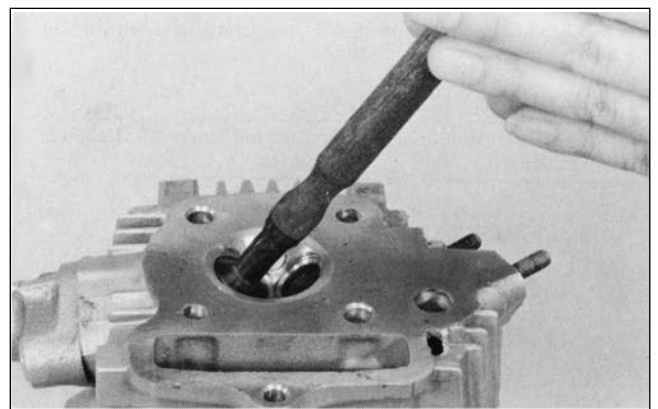
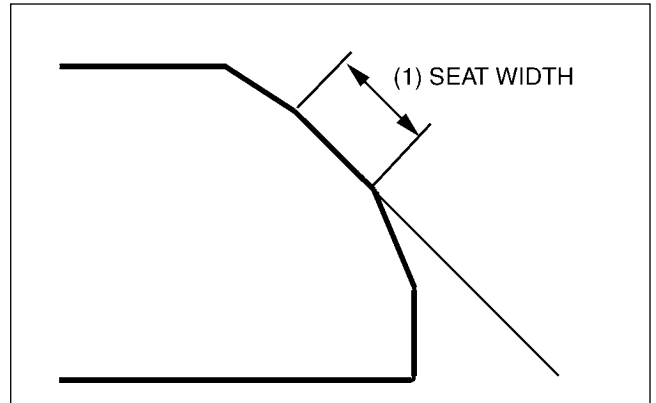

**CYLINDER HEAD / VALVES**

Install the valve spring seats, springs and retainers.

**NOTE**

Install the valve springs with the narrow pitch end facing down.

Compress the valve spring and install the valve cotters.

**CAUTION**

To prevent loss of tension, do not compress the valve spring more than necessary.

**TOOLS:**

Commercially available tools.

Tap the stems gently with a plastic hammer to firmly seat the cotters.

**CAUTION**

Support the cylinder head above the work bench surface to prevent valve damage.

Apply clean engine oil to the camshaft and camshaft bearings. Install the camshaft into the cylinder head with the cam lobes facing the combustion chamber.

**NOTE**

The camshaft can be installed after the cylinder head has been installed.

Coat the rocker arm shafts with fresh engine oil. Install the rocker arm shafts and the rocker arms.

**NOTE**

Be sure the shaft threads are facing outward.

Install a new gasket onto the right side cover, then install the cover.

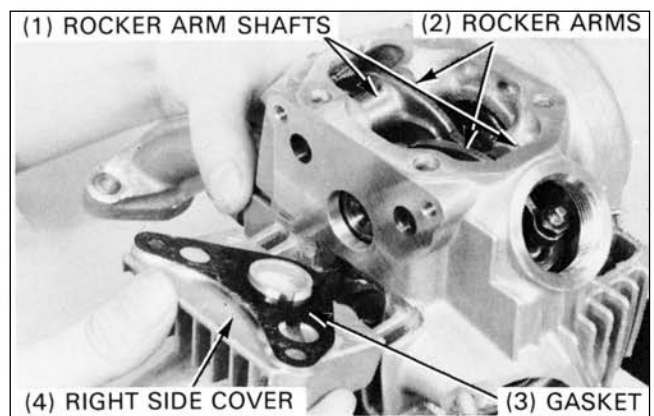
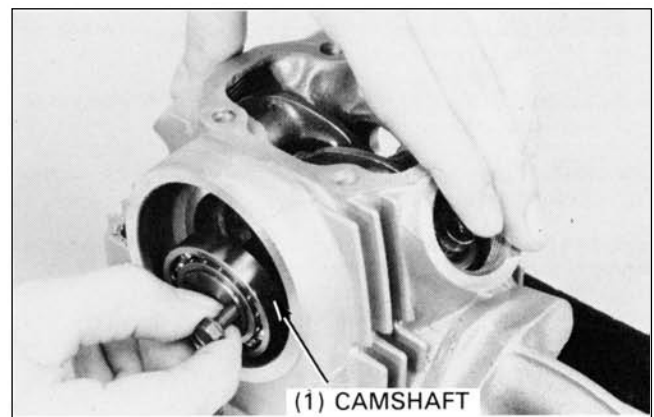
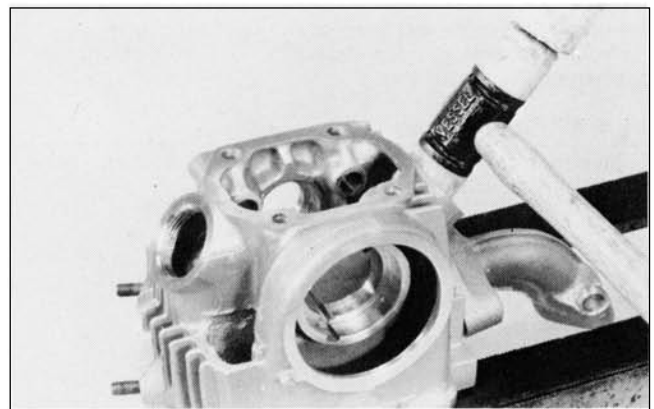
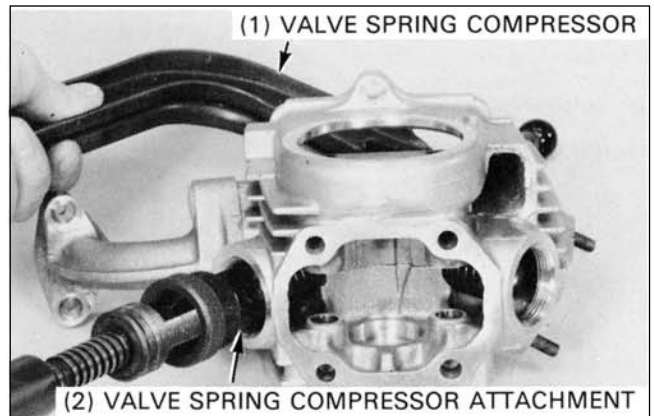

**CYLINDER HEAD / VALVES**

**CYLINDER HEAD INSTALLATION**

Clean the cylinder head gasket surface of any gasket material.

**NOTE**

Do not allow dust and dirt to enter the cylinder.

Install the dowel pins, a new cylinder head gasket, the O-rings and collars.

Install the cylinder head and a new head cover gasket.

Position the cylinder head cover with its arrow (1) facing the exhaust side.

Install the sealing washer (2), copper washer (3) and nuts (4) in the proper locations.

Tighten the cap nuts to the specified torque.

**TORQUE: 10-12 Nm**

Install the muffler in the reverse order of removal.

**TORQUE**

**Exhaust pipe joint nuts (1): 10-12 Nm**

Tighten the intake manifold bolts (2).

**TORQUE: 10 Nm**

**NOTE**

Make sure that the O-ring is positioned properly.

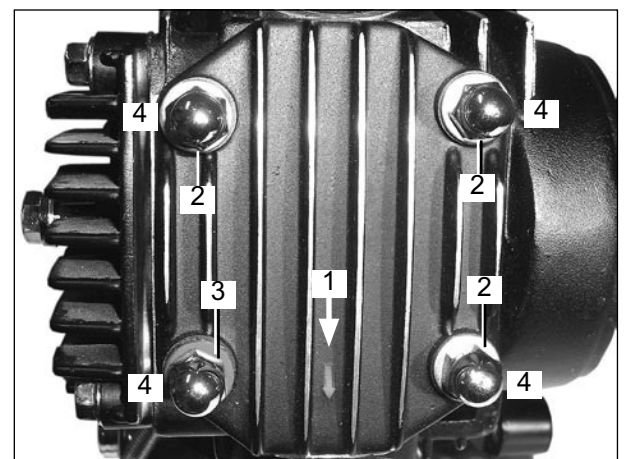
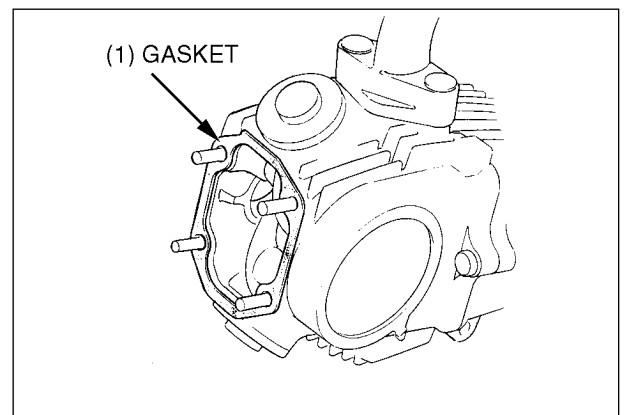
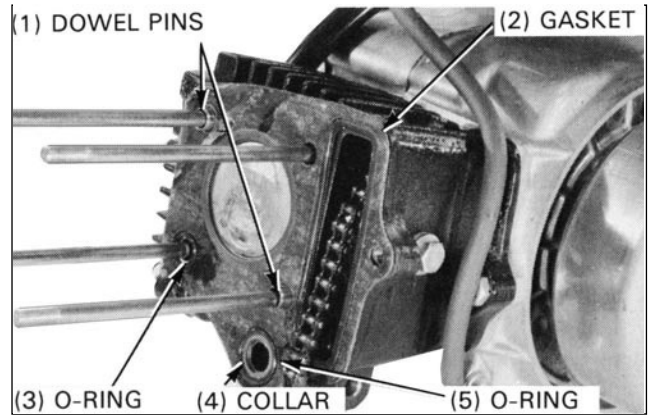

**CYLINDER HEAD / VALVES**

**CAMSHAFT INSTALLATION**

Rotate the flywheel counterclockwise and align the "T" mark with the index mark.

Coat the camshaft and camshaft bearings with clean engine oil.  
While holding the rocker arms out of the way, install the camshaft into the cylinder head with the cam lobes facing the piston.

Install the dowel pin into the camshaft.  
Align the "O" mark on the cam sprocket with the index mark on the cylinder head.  
Install the cam chain over the sprocket.

Tighten the cam sprocket bolts.

**TORQUE: 9 Nm**

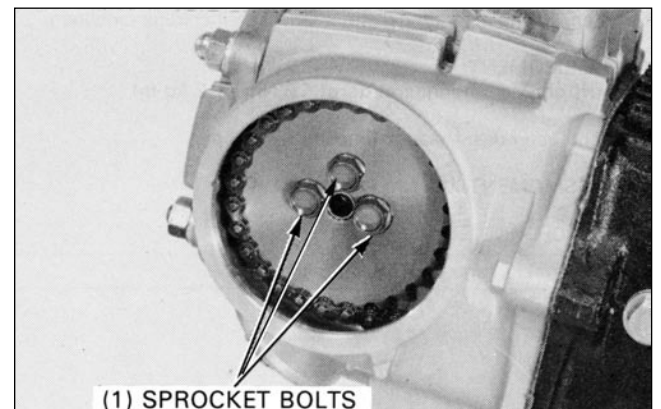
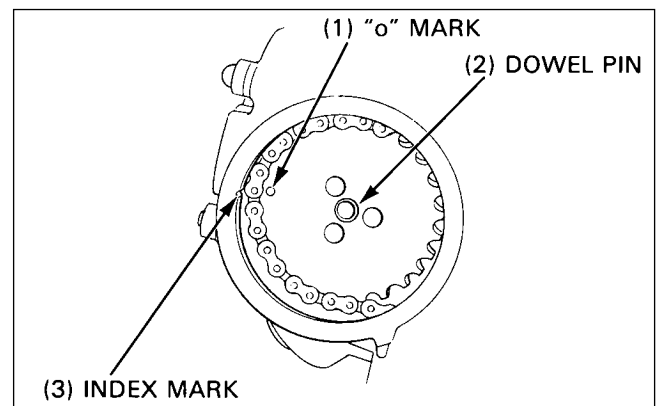
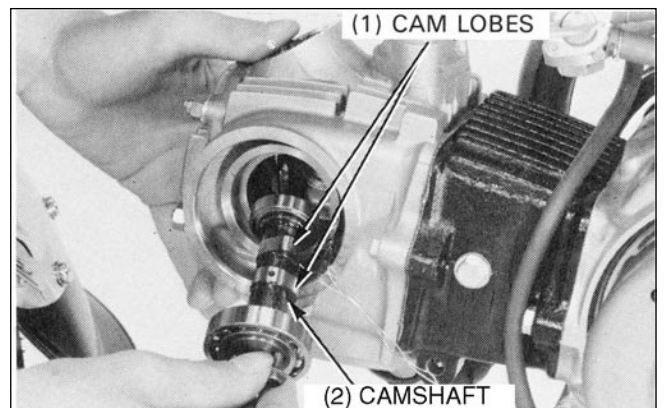
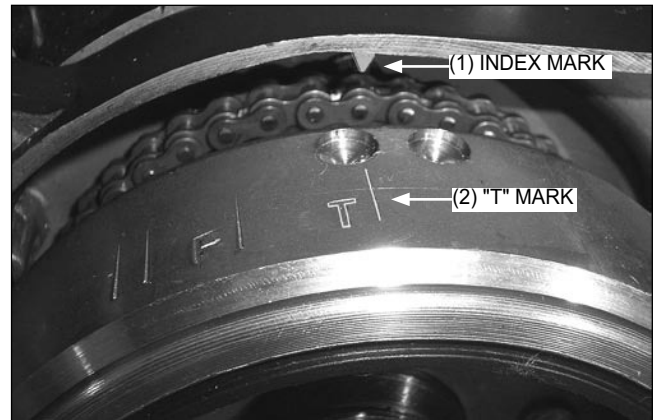

**CYLINDER HEAD / VALVES**

Install the cam chain tensioner push rod (1) and spring (2).

Install the left crankcase cover.

Install a new gasket (3) and the left side cover (4).

Adjust the valve clearance.

Install the spark plug (5).

Tighten the left side cover using the 6 mm bolt (6).

**CYLINDER COMPRESSION**

Warm up the engine.

Stop the engine and remove the spark plug (5).

Insert the compression gauge.

Move the choke lever (7) downward.

Open the throttle grip fully.

Crank the engine with the kick starter (8).

**NOTE**

Crank the engine until the gauge reading stops rising.

**COMPRESSION PRESSURE: 10-12 kg/cm<sup>2</sup> (142-171 psi)**

Low compression can be caused by:

- Improper valve adjustment
- Valve leakage
- Worn piston ring or cylinder

High compression can be caused by:

- Carbon deposits in combustion chamber or on the piston crown.

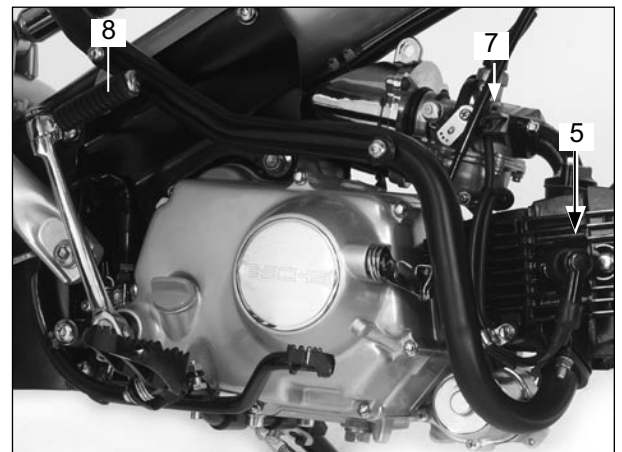
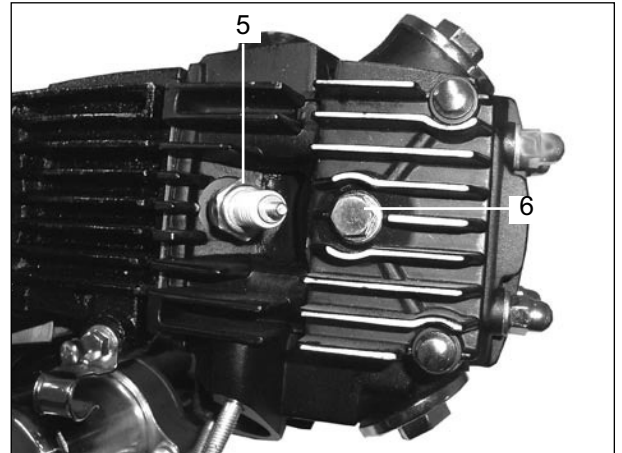
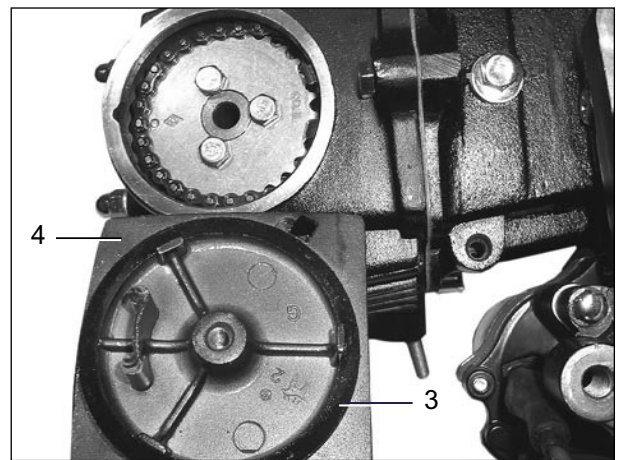
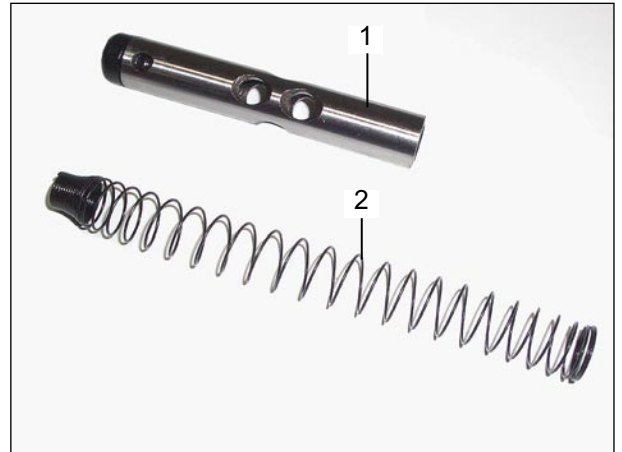

CYLINDER / PISTON

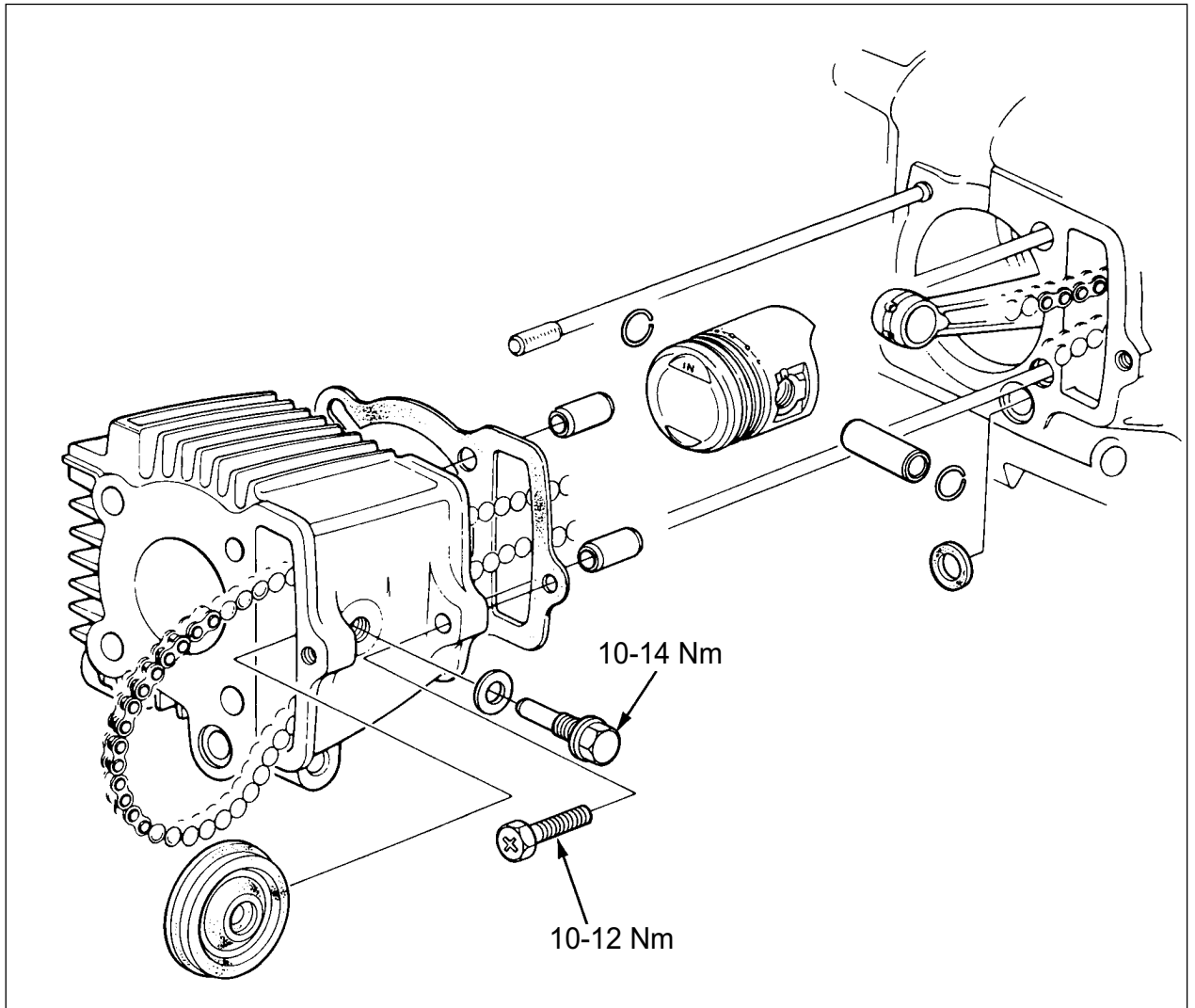



## CYLINDER / PISTON

### SERVICE INFORMATION

#### GENERAL

- This section covers the Service of the piston and cylinder. These Services are completed with the engine in the frame.
- The camshaft lubricating oil is fed to the cylinder head through an oil orifice in the right crankcase. Be sure this orifice is not clogged and that the O-ring and dowel pins are in place before installing the cylinder.

#### SERVICE DATA

Unit: mm

ITEM		STANDARD	SERVICE LIMIT
Cylinder	I.D.	52.405-52.42	52.45
	Warpage	---	0.05
	Out of round	---	0.005
	Taper	---	0.005
Piston	O.D.	52.373-52.387	52.30
	Piston pin bore	14.002-14.008	14.05
	Cylinder-to-piston clearance	0.010-0.045	0.15
Piston pin	O.D.	13.994-13.999	13.98
	Piston-to-pin clearance	---	0.075
Piston ring	End gap	Top/second	0.15-0.35
		Oil (side rail)	0.30-0.90
	Piston-to-ring groove clearance	Top	0.015-0.050
		Second	0.015-0.050
Connecting rod small end	I.D.	14.016-14.034	14.06
	Small end-to-piston pin clearance	0.016-0.040	0.08

#### TORQUE VALUES

Cylinder bolt	10-12 Nm
Cam chain guide roller pin bolt	10 Nm

#### TROUBLESHOOTING

##### Low or unstable compression

- Worn cylinder or piston rings

##### Excessive smoke

- Worn cylinder, piston or piston ring
- Improper Installation of piston rings
- Scored or scratched piston or cylinder wall

##### Overheating

- Excessive carbon build-up on piston or combustion chamber wall

##### Knocking or abnormal noise

- Worn piston and cylinder
- Excessive carbon build-up

**CYLINDER / PISTON**

**CYLINDER REMOVAL**

Remove the cylinder head.  
Remove the guide roller bolt and cam chain guide roller.

Remove the 6 mm bolt and cylinder.

Remove the O-ring, gasket and dowel pins.

**CYLINDER INSPECTION**

Inspect the cylinder bore for wear or damage.  
Measure the cylinder I.D. at three places; the top, middle and bottom areas of piston travel, and in two directions at right angles to each other.

**SERVICE LIMITS: 39.05 mm**

Measure the piston O.D. and calculate the piston-to-cylinder clearance using the maximum cylinder I.D. measurement.

**SERVICE LIMIT: 0.15 mm**

Measure the cylinder for taper at three levels in an X and Y axis. Take the maximum reading to determine the taper.

**SERVICE LIMIT: 0.10 mm**

Measure the cylinder for out-of-round at three levels in an X and Y axis. Take the maximum reading to determine the out-of-round.

**SERVICE LIMIT: 0.10 mm**

Check the cylinder for warping with a straight edge and a feeler gauge.

**SERVICE LIMIT: 0.05 mm**

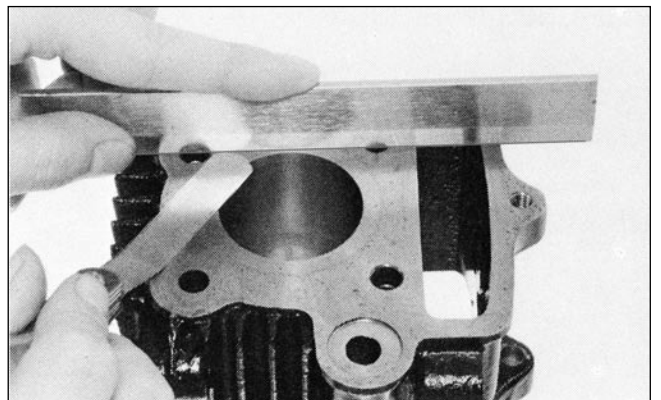
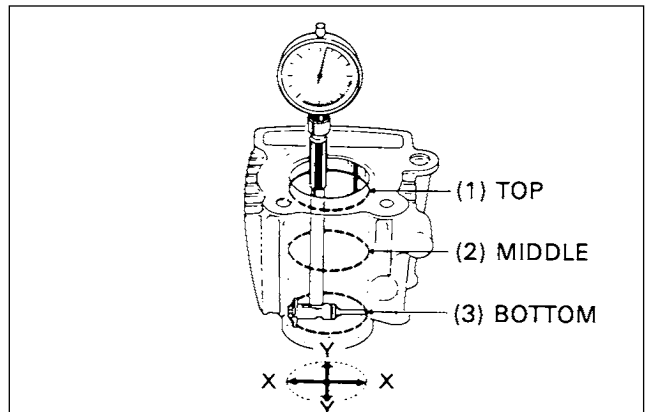
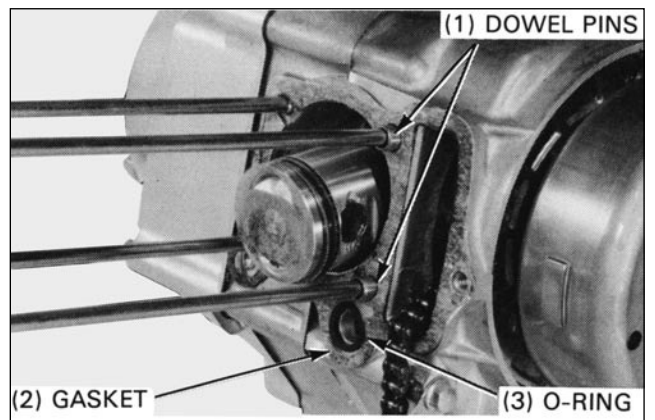
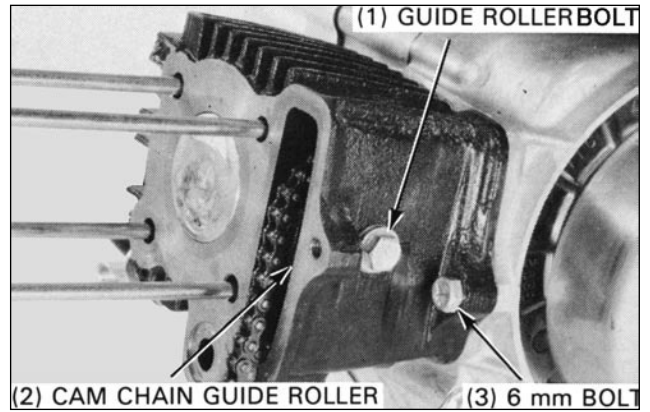

**CYLINDER / PISTON**

**PISTON REMOVAL**

Place clean shop towels in the crankcase to keep the piston pin clips or other parts from falling into the crankcase.

Remove the piston pin clip with pliers.  
Press the piston pin out of the piston from the opposite side with your finger.

Remove the piston.

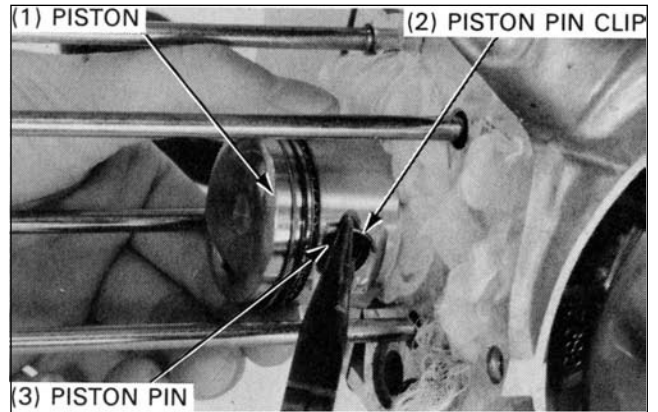

**PISTON/PISTON RING INSPECTION**

Measure the piston ring-to-groove clearance with a feeler gauge.

**SERVICE LIMITS:**

**Top: 0.12 mm**  
**Second: 0.12 mm**



Measure the piston O.D. at the skirt.

**SERVICE LIMIT: 38.90 mm**

Compare this measurement against the service limit and use it to calculate piston-to-cylinder clearance.



Measure the piston pin bore I.D. in two directions at right angles to each other.

**SERVICE LIMIT: 13.05 mm**

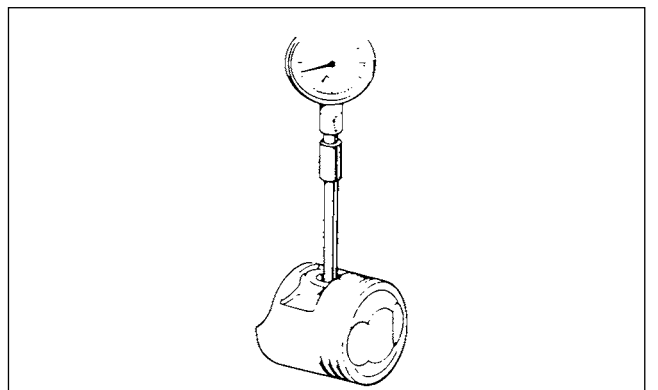

**CYLINDER / PISTON**

Measure the piston pin O.D. at the left, center and right in two directions at right angles to each other.

**SERVICE LIMIT: 12.98 mm**

Calculate the piston-to-piston pin clearance.

**SERVICE LIMIT: 0.08 mm**

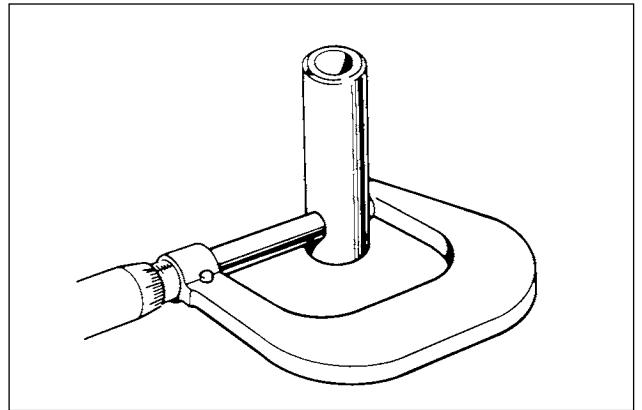

Measure the connecting rod small end I.D.

**SERVICE LIMIT: 13.06 mm**

Calculate the piston pin-to-connecting rod clearance.

**SERVICE LIMIT: 0.03 mm**

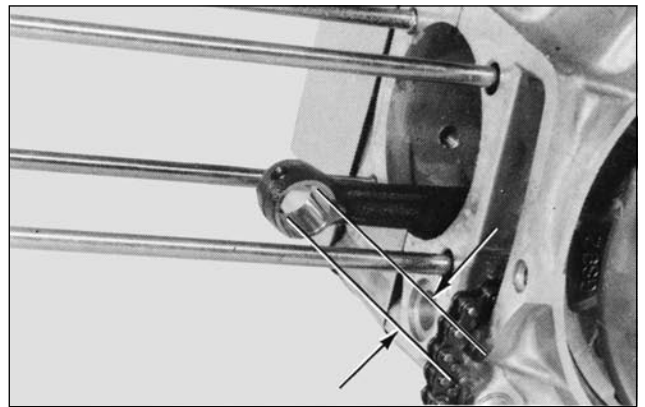

Remove the piston rings.

**NOTE**

Do not damage the rings during removal.

Inspect the piston ring for damage or cracks.

Inspect the piston groove for wear or damage.

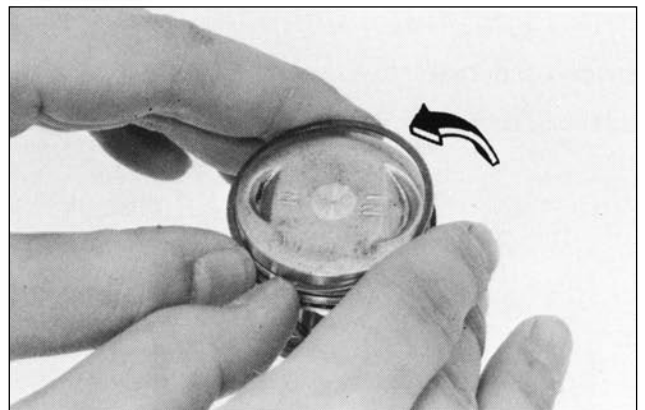

Insert each piston ring into the cylinder with the piston and measure the ring end gap in the cylinder at a point 10 mm from the bottom.

**SERVICE LIMITS:**

**Top/second: 0.5 mm**

**Oil (side rail): 1.1 mm**



**CYLINDER / PISTON**

**PISTON RING INSTALLATION**

Clean the piston ring grooves thoroughly and install the piston rings with the markings facing up.

**NOTE**

When installing the oil ring, install the spacer first and then the side rails.

Be careful not to damage the piston or rings during installation.

After Installation, the piston rings should be free to rotate in the grooves.

Do not interchange the top ring with the second ring.

Space the piston ring end gaps 120° apart.

Do not align the gaps of the oil ring side rails.

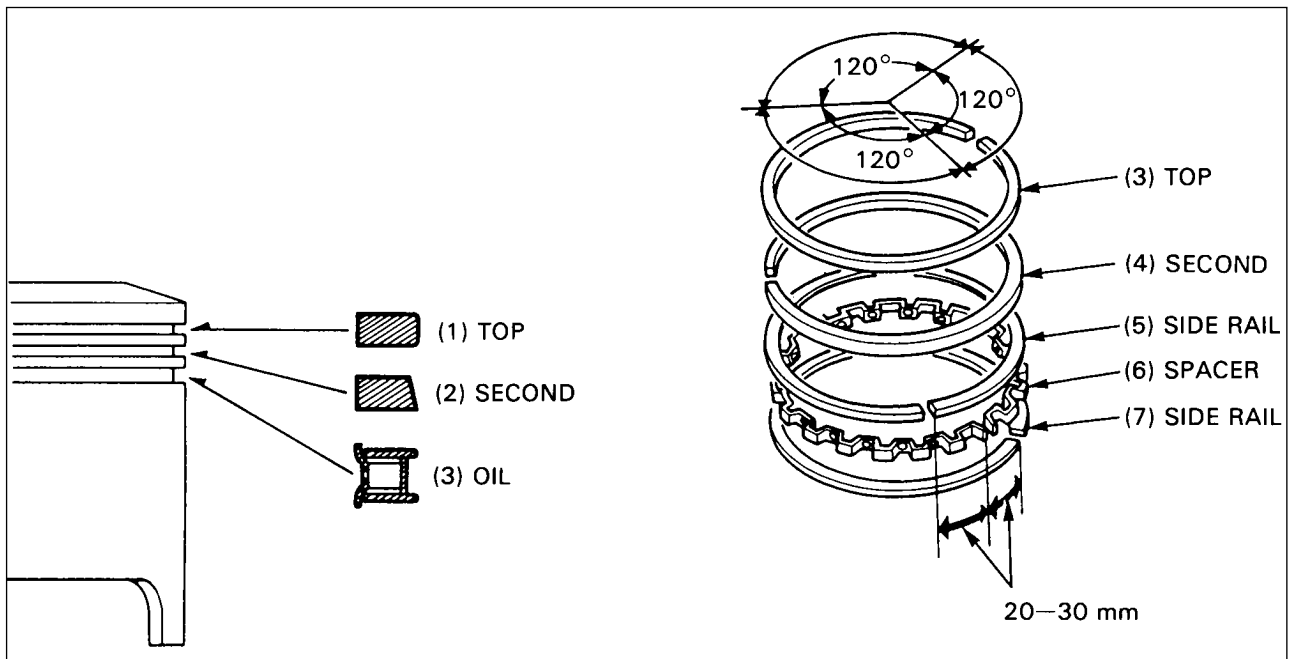

**PISTON INSTALLATION**

Install the piston with the "IN" mark facing the intake valve. Install the piston pin and new piston pin clips.

**NOTE**

Replace piston pin clips whenever they are removed.

Do not align the piston pin clip end gap with the piston cutout.

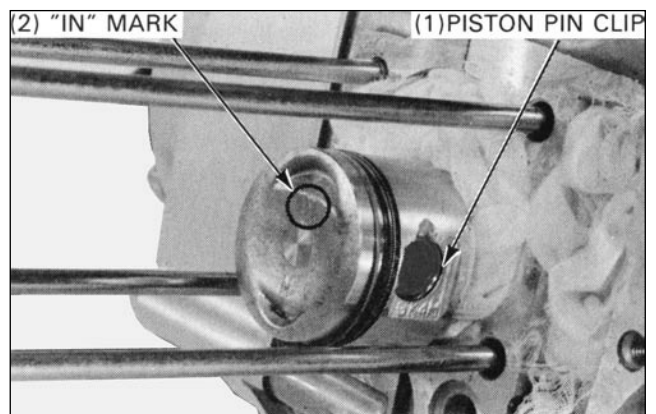

**CYLINDER / PISTON**

**CYLINDER INSTALLATION**

Remove any gasket material from the cylinder gasket surface on the crankcase.

**NOTE**

Do not damage the gasket surface.

Do not let any material fall into the crankcase.

Install a new cylinder gasket, O-ring and dowel pins.

**NOTE**

Make sure that the oil orifice is not clogged.

Coat the cylinder and piston rings with clean engine oil and install the cylinder.

**NOTE**

Be careful not to damage the piston rings during installation.

Tighten the 6 mm cylinder bolt.

**TORQUE: 10-12 Nm**

Install the cam chain guide roller and tighten the roller bolt.

**TORQUE: 10 -14 Nm**

Route the carburetor drain tube properly.

Install the cylinder head.

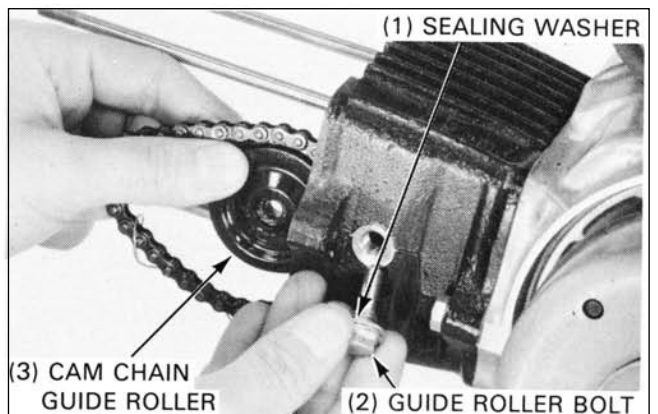
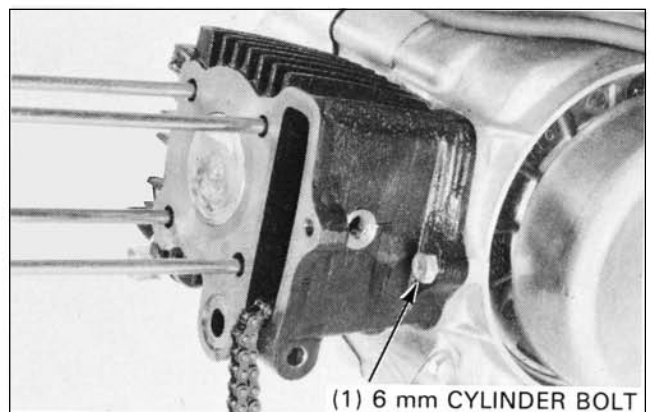
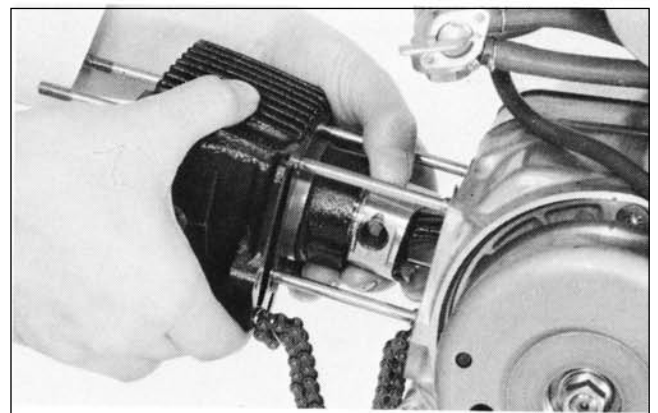
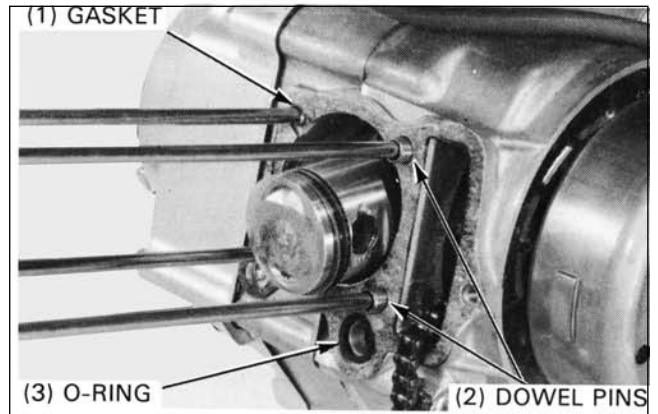

## CLUTCH/GEARSHIFT LINKAGE

### SERVICE INFORMATION

#### GENERAL

This section covers removal, installation and servicing of the clutch and gearshift linkage with the right crankcase cover removed.

All these operations can be accomplished with the engine in the frame. When the existing clutch discs are replaced, coat new discs with clean engine oil prior to assembly.

See section for oil pump Service.

#### SERVICE DATA

Unit: mm

ITEM		STANDARD	SERVICE LIMIT
Clutch	Spring free length	20	18
	Plate warpage	—	0.2
	Disc thickness	3.86-3.90	3.60
	Clutch center guide O.D.	20.840-20.860	20.80
	Primary drive gear I.D.	21.000-21.021	21.05

#### TORQUE VALUES

Clutch lock nut	40-45 Nm
Shift drum stopper arm bolt	10 Nm
Shift drum stopper plate bolt	14-20 Nm
Crankcase cover bolt	8-12 Nm

#### TOOLS

Special	
Clutch outer holder	07923-0340000

#### Common

Lock nut wrench, 20 x 24 mm
Extension bar

#### TROUBLESHOOTING

##### CLUTCH

Clutch slips when accelerating

- Incorrect clutch adjustment
- Discs worn
- Spring damaged

Motorcycle creeps with clutch disengaged

- Incorrect clutch adjustment
- Plate warped
- Faulty clutch lifter

##### GEARSHIFT LINKAGE

Hard to shift

- Damaged gearshift spindle
- Damaged stopper plate and pin
- Loose stopper plate bolt
- Incorrect clutch adjustment

Transmission Jumps out of gear

- Damaged stopper arm
- Damaged stopper plate
- Loose stopper plate bolt

**CLUTCH/GEARSHIFT LINKAGE**

**RIGHT CRANKCASE COVER REMOVAL**

Drain the oil from the engine.

Support the motorcycle using a safety stands and remove the side stand with the footrest by removing the four bolts (1).

Disconnect the clutch pull cable (2).

Remove the kick starter pedal (3).

Remove eight screws and take off the right crankcase cover (4).

Remove the gasket (5) and two dowel pins (6).

**CLUTCH REMOVAL**

Remove the clutch outer cover (7) by removing the four screws (8).

Straighten the lock washer tab (9).

Hold the clutch outer with a clutch holder.

**TOOL:**

**Crownnut wrench**

Remove the lock nut (10) with a lock nut wrench and extension bar.

Remove the plain washer and lock washer.

Remove the clutch assembly (11).

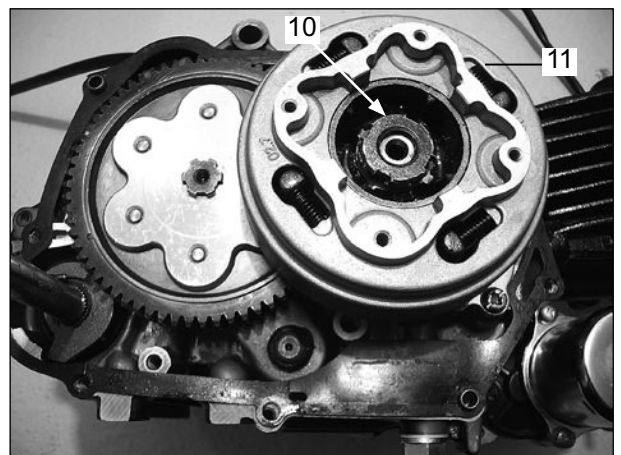
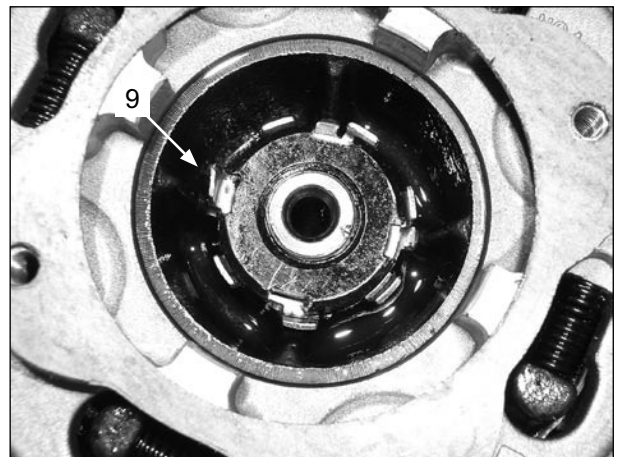
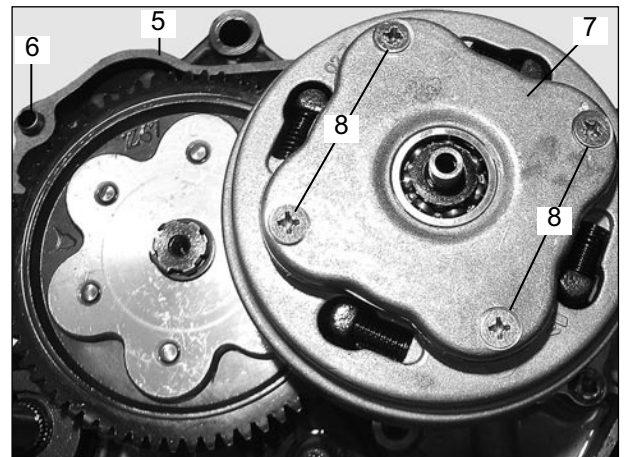
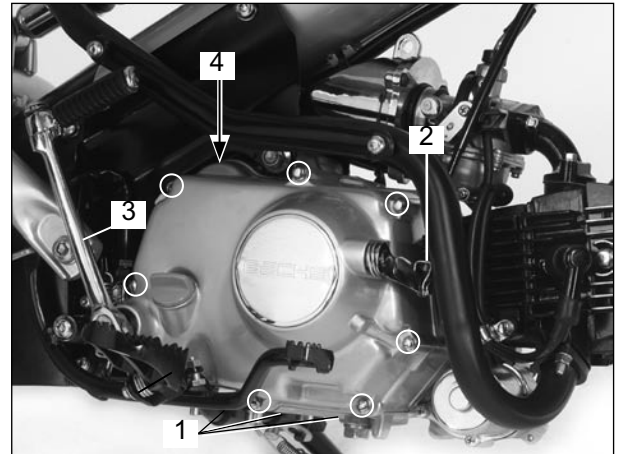



**CLUTCH/GEARSHIFT LINKAGE**

Remove the primary drive clutch (1) and clutch center guide (2).

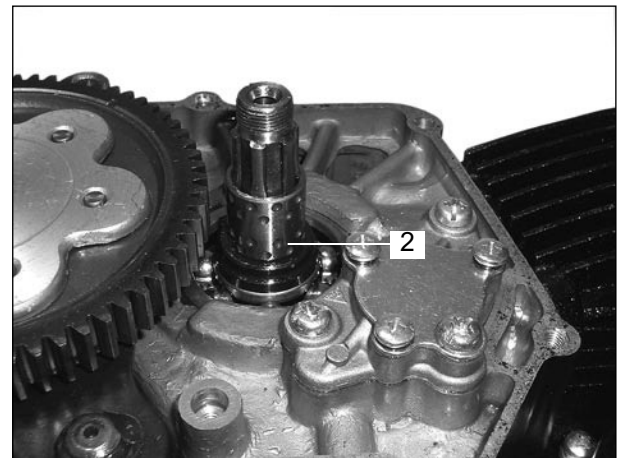

**CLUTCH/GEARSHIFT LINKAGE**

Remove the snap ring (2) and the primary driven gear (1).

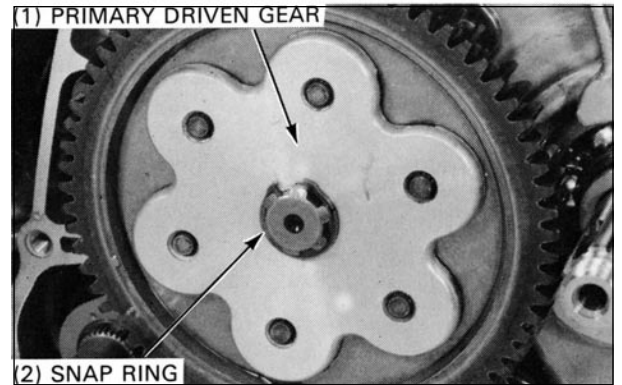

Remove the collar (3) from the crankshaft.

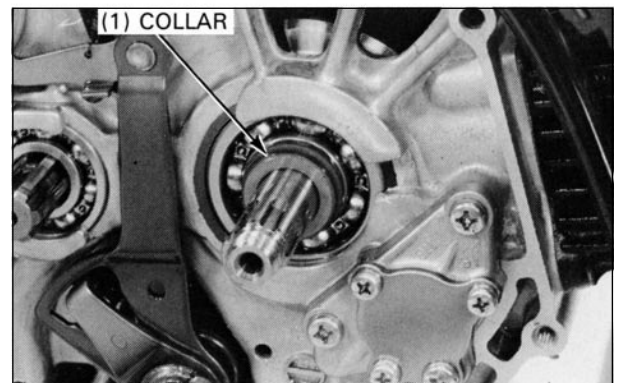

**CLUTCH DISASSEMBLY**

Remove the set ring (1).

Remove the clutch plates (2), friction discs and clutch center (3).

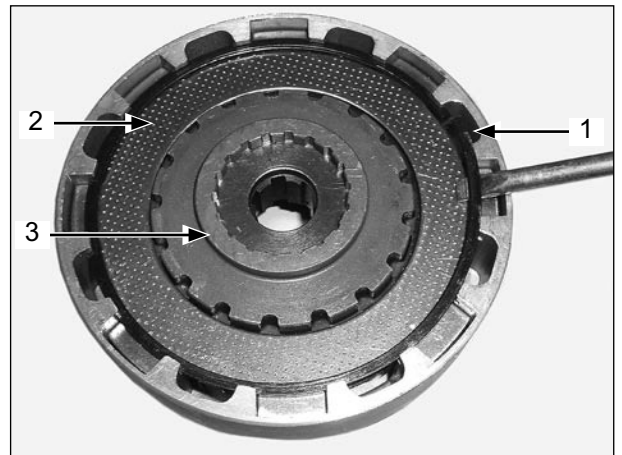

Remove the damper springs (4).

Separate the drive plate (5) and clutch springs from the clutch outer (6).

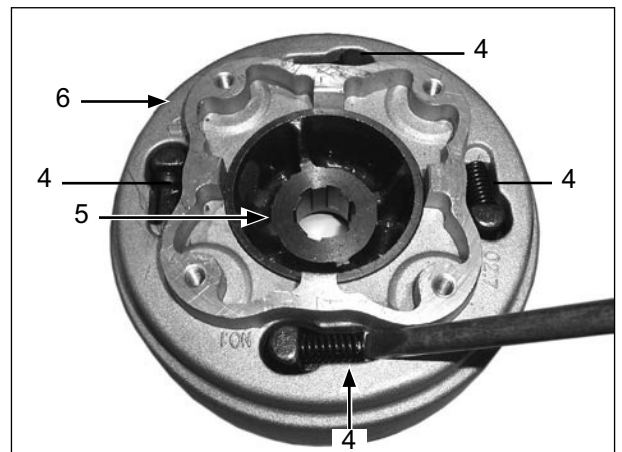

**CLUTCH/GEARSHIFT LINKAGE**

1	Clutch outer
2	Drive plate
3	Clutch center
4	Friction disc
5	Clutch plate
6	Friction disc
7	Clutch plate
8	Set spring
9	Damper spring
10	Clutch spring

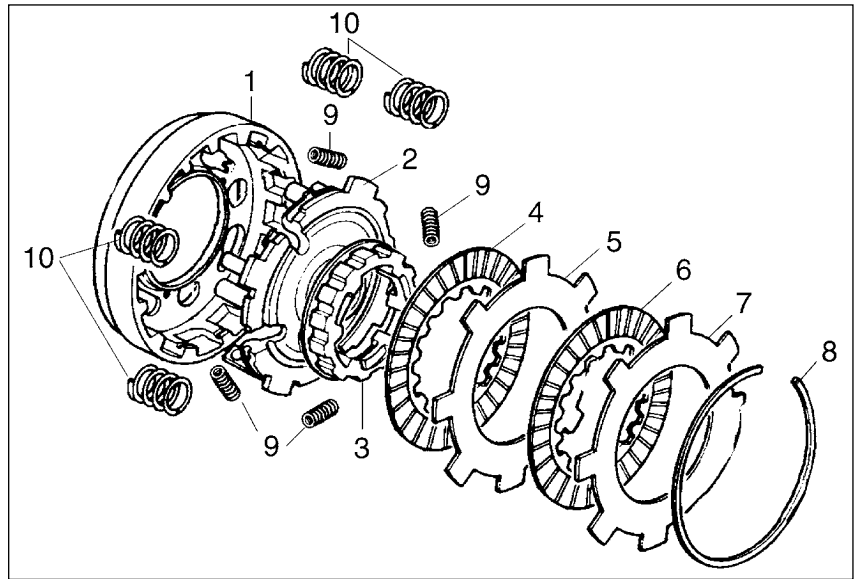

**INSPECTION**

Friction discs

Replace the friction discs if they show signs of scoring or discoloration.

Measure each friction disc thickness.

**SERVICE LIMITS:**

**Discs 4 and 6: 2.3 mm**

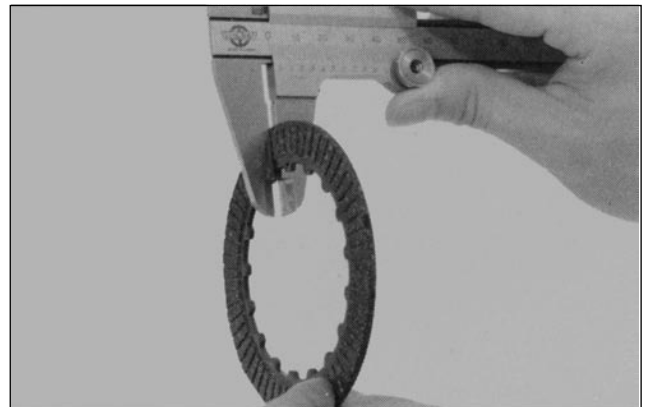

Clutch plates

Check the plates for warpage on a surface plate, using a feeler gauge.

**SERVICE LIMIT:**

**Plate 5 and 7: 0.2 mm**

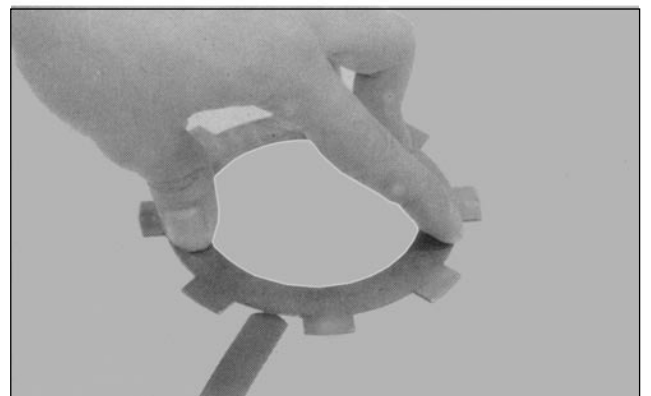

**CLUTCH/GEARSHIFT LINKAGE**

**Primary Drive Gear/Center Guide**

Check the primary drive gear and the center guide for wear or damage.

Inspect the primary drive gear I.D. and the center guide O.D.

**SERVICE LIMITS:**

**Primary drive gear I.D.:** 21.05 mm

**Center guide O.D.:** 20.90 mm

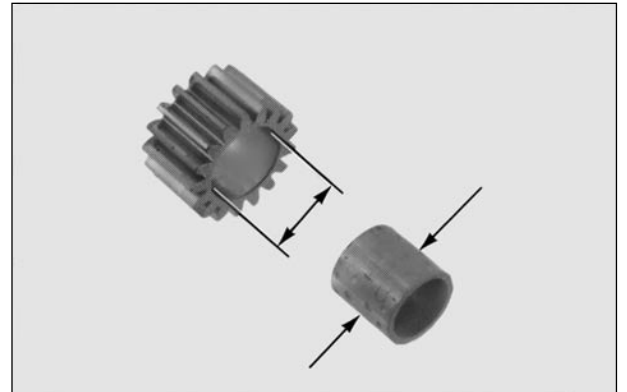

**Clutch Spring**

Measure each clutch spring free length.

**SERVICE LIMIT:** 17.5 mm

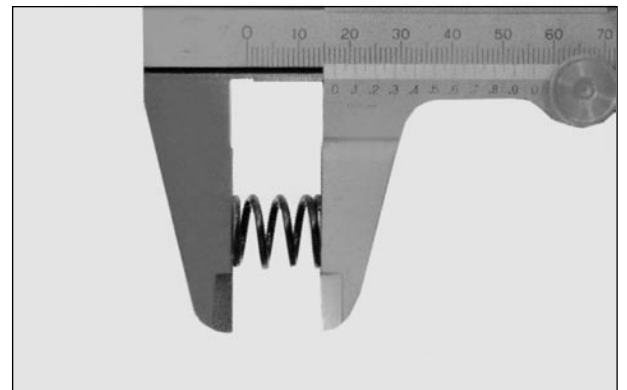

**CLUTCH ASSEMBLY**

Install the four clutch springs (1) on the clutch outer.



**NOTE**

Coat the clutch discs with lightweight engine oil before assembling.

Assemble the drive plate (2) with the friction discs (3), clutch plates (4) and the clutch center (5).

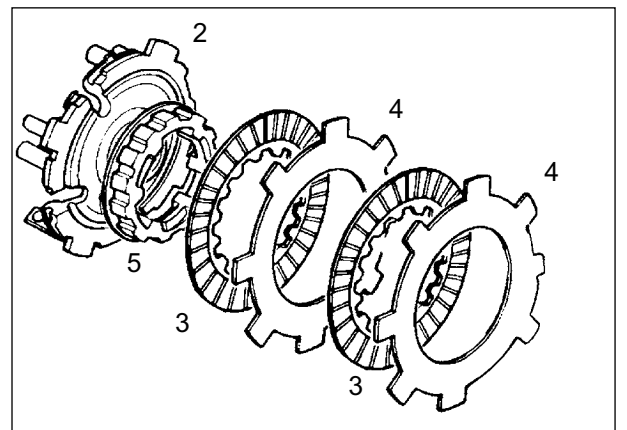

**CLUTCH/GEARSHIFT LINKAGE**

Install the assembly (1) into the clutch outer (2).

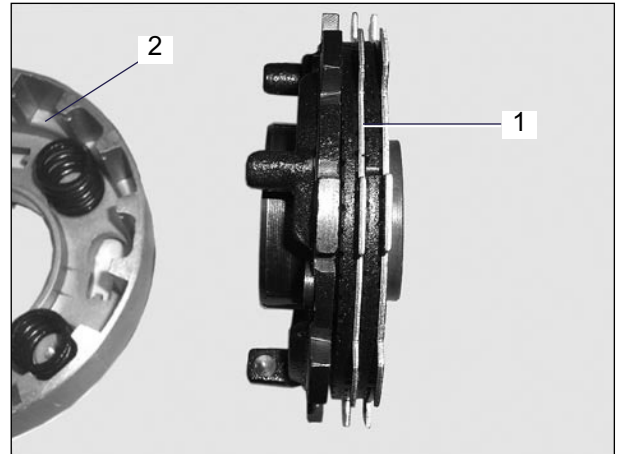

Install the set ring (3).

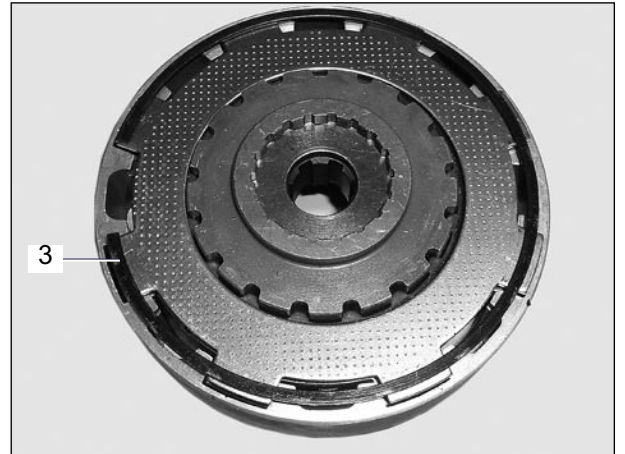

Install the clutch damper springs (4).

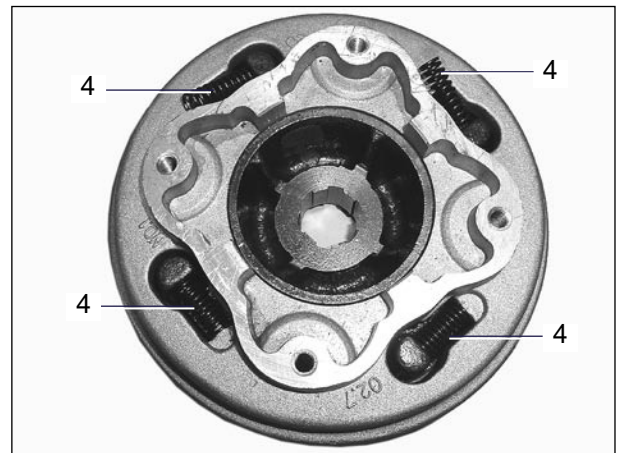

**CLUTCH/GEARSHIFT LINKAGE****GEARSHIFT LINKAGE****DISASSEMBLY**

Remove the bolt (1), drum Stopper arm (2) and spring (3).

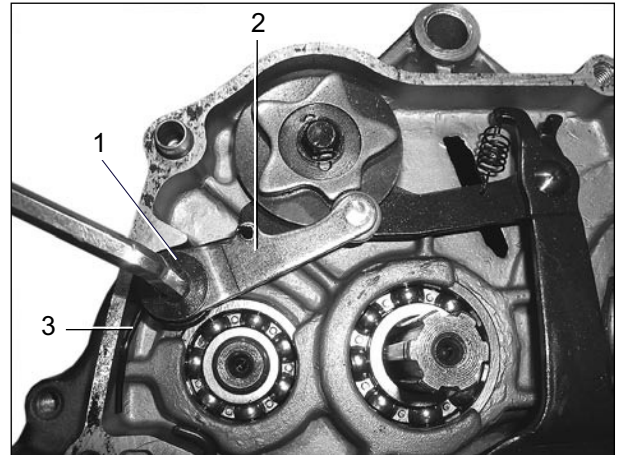

Remove the gearshift pedal.

Hold the gearshift spindle claw (4) down and pull out the gearshift spindle (5).

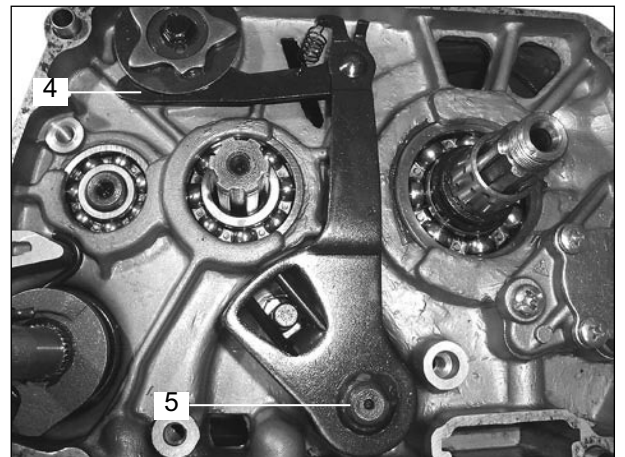

Remove the stopper plate bolt (6) and the plate (7).

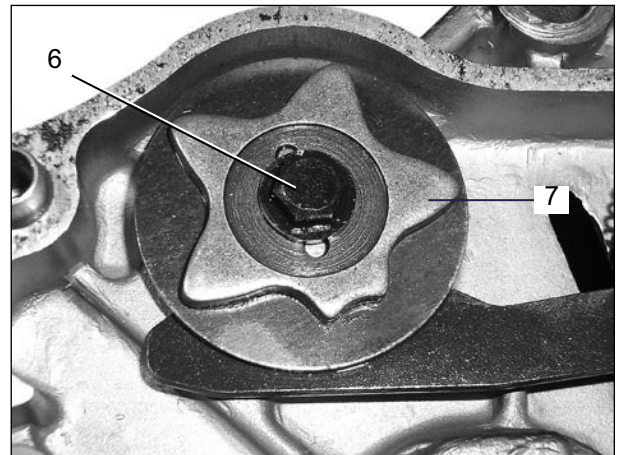
**ASSEMBLY**

Install the gearshift linkage in the reverse order of removal.

**NOTE**

Align the holes (1) in the stopper plate with the dowel pins (2).

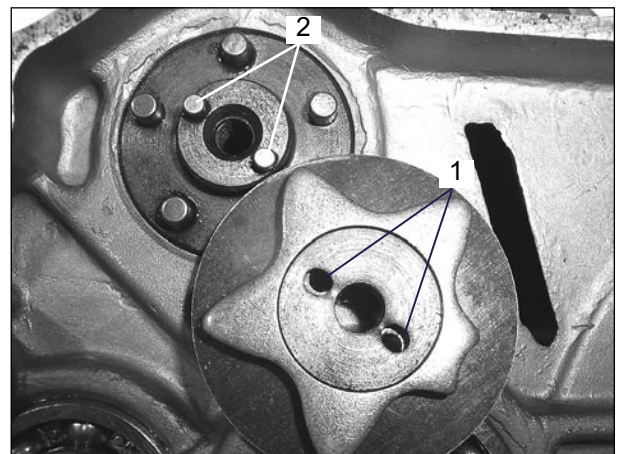

**CLUTCH/GEARSHIFT LINKAGE**

Install the gearshift spindle (3) and stopper arm (4).

**TORQUE:**

Stopper arm bolt	10 Nm
Stopper plate bolt	17 Nm

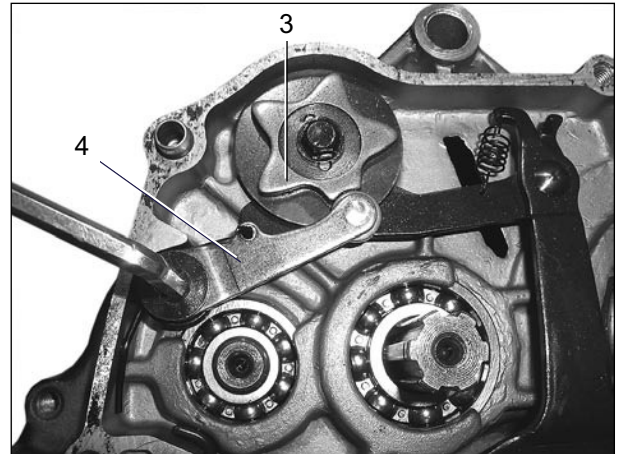

**CLUTCH INSTALLATION**

Install the collar (1) onto the crankshaft.

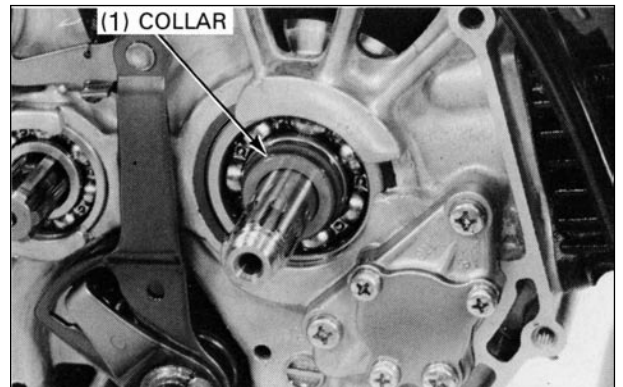

Install the primary driven gear (2) and secure it with the snap ring (3).

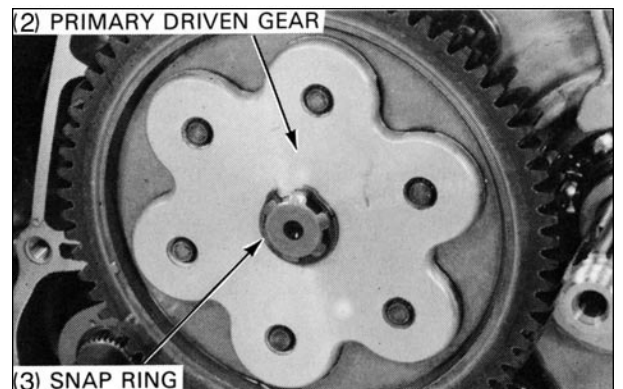

**CLUTCH/GEARSHIFT LINKAGE**

Install the clutch center guide (1) and primary drive gear (2) onto the crankshaft.

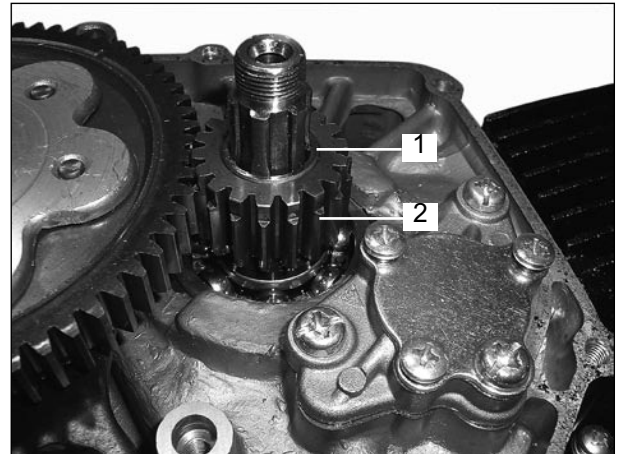

Install the clutch assembly (3).

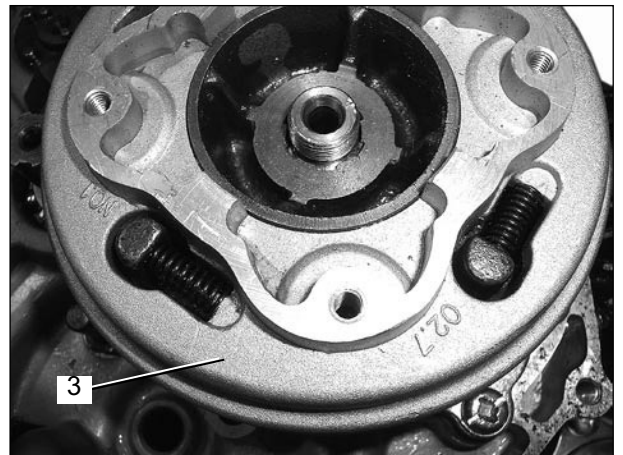
**NOTE**

Install a new lock washer (4).

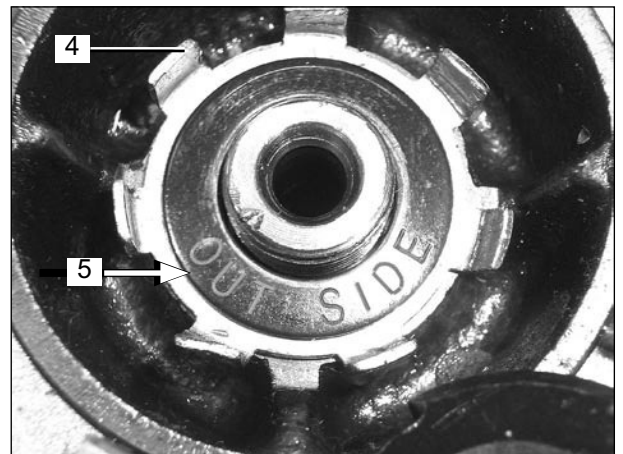

Install the plain washer (5) with the "OUTSIDE" mark facing out.

Hold the clutch outer with the clutch outer holder.

Tighten the lock nut (6) with the lock nut wrench and extension bar.

**TOOL:**

**Crownnut wrench**

**TORQUE: 40-45 Nm**

Bend the tab (7) of the lock washer up against the groove in the lock nut.

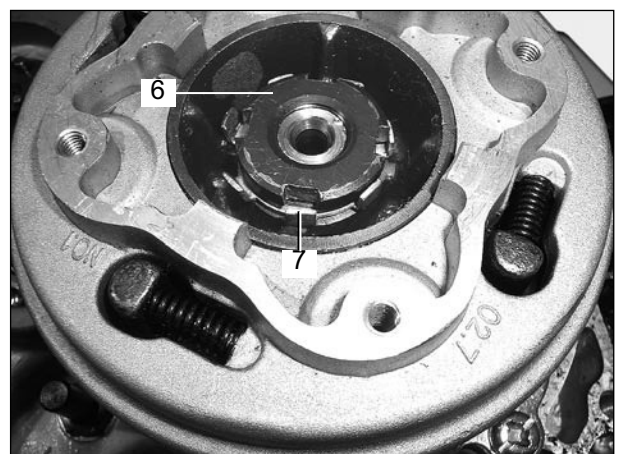



## CLUTCH/GEARSHIFT LINKAGE

Install a new gasket for the clutch outer cover (1) and tighten them with four screws (2).

Install the bushing (3) with the spring.

Set in the two dowel pins (4) into the crankcase and use a new gasket (5).

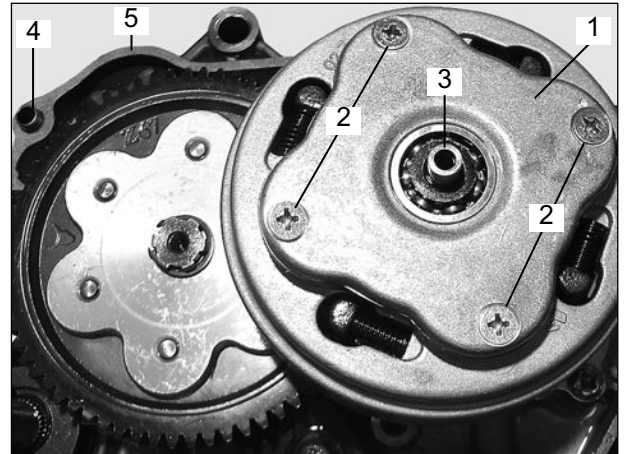

Clean the oil filter screen (6) and install into the crankcase.

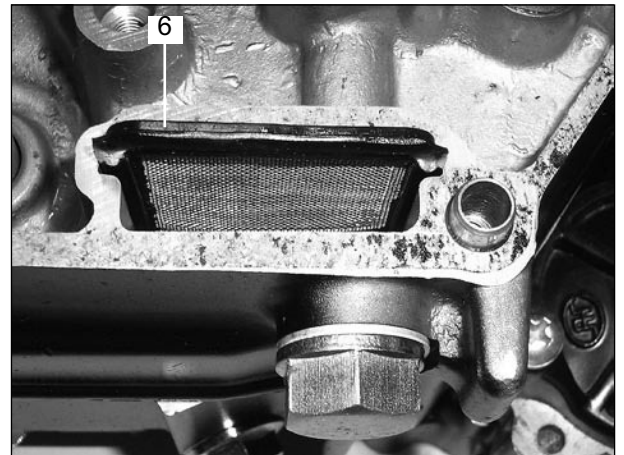

## RIGHT CRANKCASE COVER INSTALLATION

Install the crankcase cover (7) using eight bolts.

Install the kick starter pedal (8) and connect the clutch pull cable (9).

Adjust the clutch.

Fill up crankcase with engine oil.

**SAE 15 W 40 engine oil API (SG or higher)  
0.8 lit.**

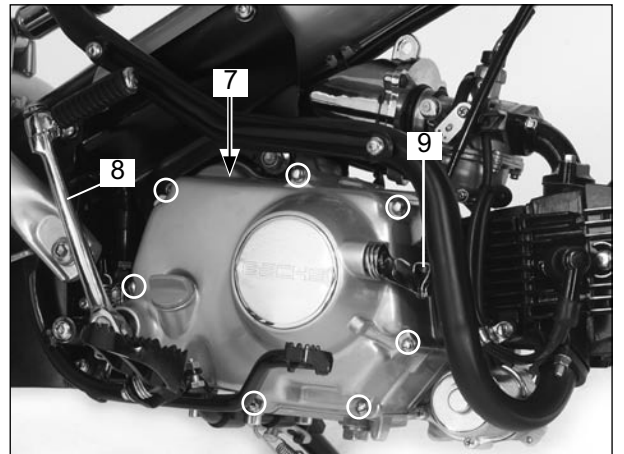

**ALTERNATOR / CAM CHAIN TENSIONER**

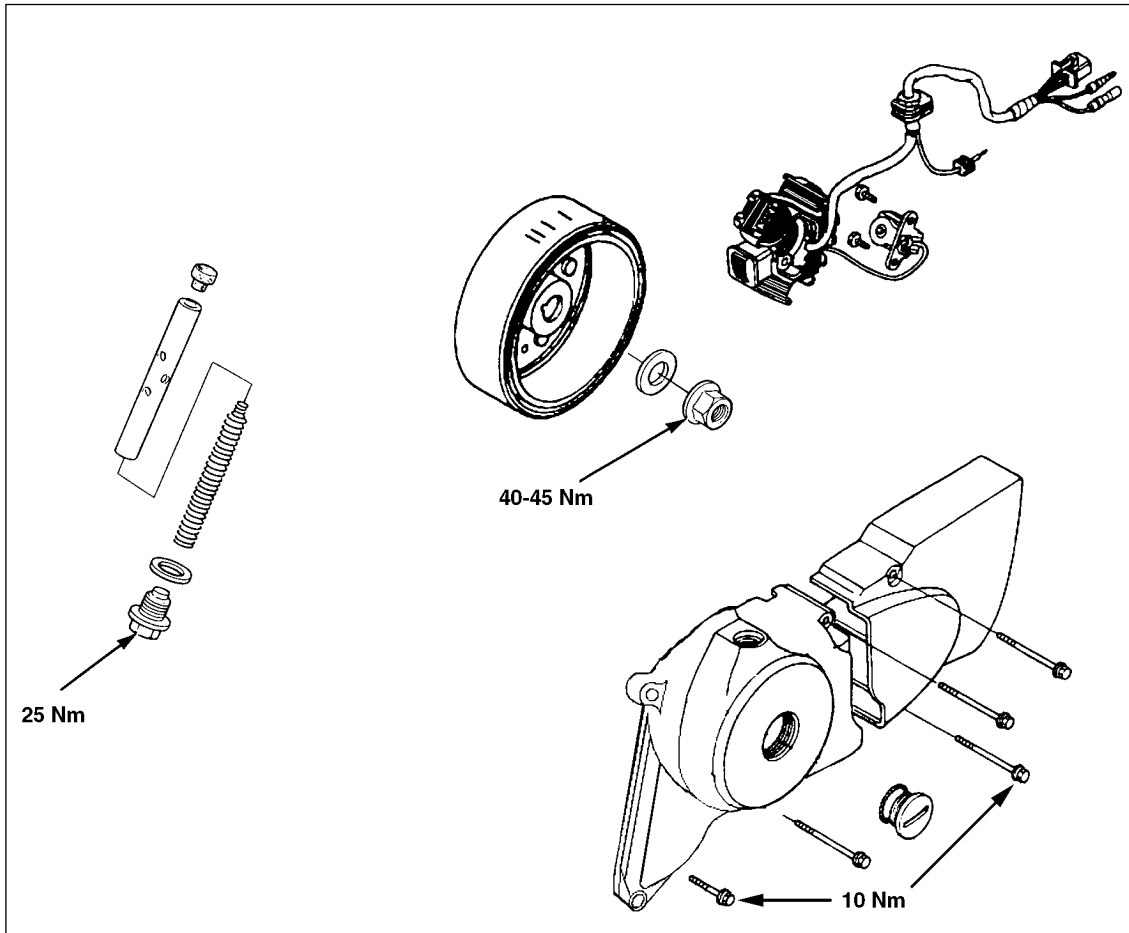

**SERVICE INFORMATION**

**GENERAL**

This section contains information for the removal and installation of the alternator and cam chain tensioner. These operations can be accomplished with the engine in the frame after removing the left crankcase cover. For alternator inspection and troubleshooting, refer to sections 13 and 14.

**SERVICE DATA**

Unit: mm

ITEM		STANDARD	SERVICE LIMIT
Cam chain tensioner	Tensioner spring free length	111.70	106.70
	Push rod O. D.	11.985-12.000	11.94

**TORQUE VALUES**

Flywheel nut	40-45 Nm
Sealing bolt	25 Nm
Left crankcase cover bolt	10 Nm

**TOOLS**

- Common
- Universal holder
- Flywheel puller

**TROUBLESHOOTING**

**Excessive cam chain slack**

- Worn or damaged tensioner spring
- Faulty push rod (clogged one-way valve)
- Damaged cam chain tensioner

**Cam chain noise**

- Worn or damaged tensioner spring
- Faulty push rod (clogged one-way valve)
- Damaged cam chain tensioner
- Air in tensioner chamber
- Sticking push rod

**ALTERNATOR / CAM CHAIN TENSIONER**

**ALTERNATOR REMOVAL**

Remove the gearshift pedal (1).

Reinstall four bolts (2) and remove the left crankcase cover (3).

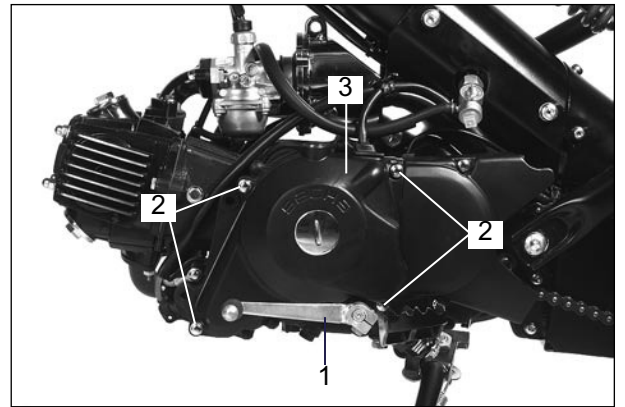

**FLYWHEEL REMOVAL**

Hold the flywheel (4) with the universal holder and remove the 10 mm nut.

**TOOL:**

**Universal holder**

**Flywheel puller M28x1**

Remove the flywheel using the flywheel puller.

Remove the woodruff key from the crankshaft.

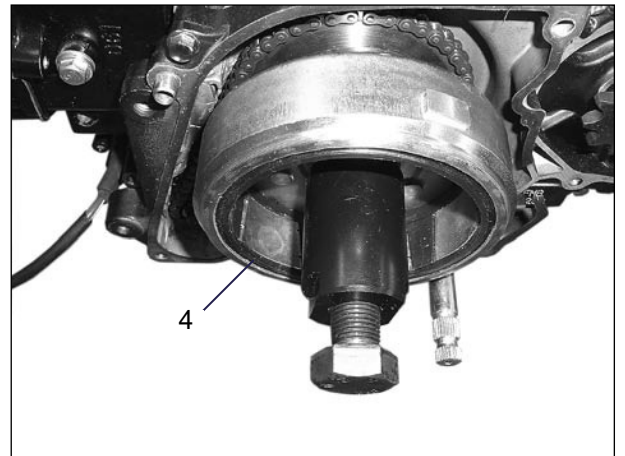

**CAM CHAIN TENSIONER**

**INSPECTION**

Remove bolt (1).

Measure the spring free length.

**Service limit: 106 mm**

Check the sealing washer (2) and replace if it appears worn.

Check the push rod for wear or scratches and the valve holes for clogging.

Measure the push rod O.D.

**Service limit: 11.94 mm**

**INSTALLATION**

Assembly takes place in reverse order of removal.

**Torque bolt (1): 25 Nm**

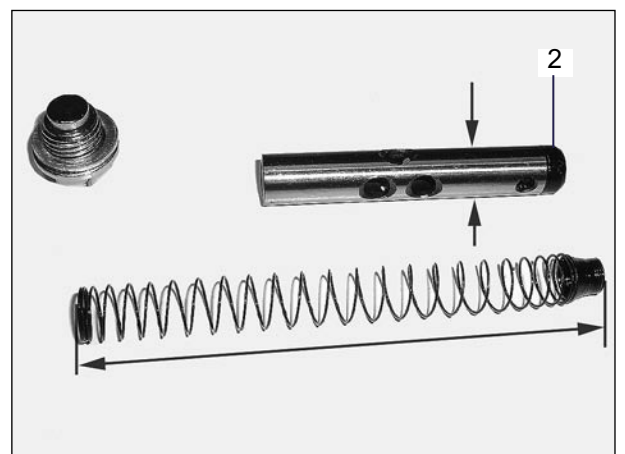
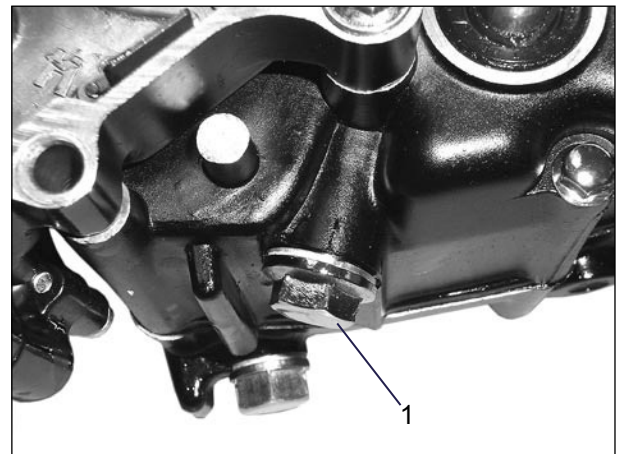

## TRANSMISSION / CRANKSHAFT / KICK STARTER

### SERVICE INFORMATION

#### GENERAL

The crankcase must be separated to Service the components covered in this section.  
The following parts/systems must be removed before the crankcase can be separated:

- Engine removal
- Cylinder head
- Cylinder/piston
- Clutch/gearshift linkage
- Alternator/cam chain tensioner
- Oil pump

#### SERVICE DATA

Unit: mm

ITEM		STANDARD	SERVICE LIMIT	
<b>Crankshaft</b>	Connecting rod small end I.D.	14.016-14.034	14.06	
	Connecting rod big end clearance	Axial	0.100-0.350	
		Radial	0.004-0.012	
	Runout	—	0.10	
<b>Transmission</b>	Mainshaft O.D.	M2	16.966-16.984	
	Countershaft O.D.	C1	16.966-16.984	
	Gearshift fork	I.D.	34.000 34.025	34.14
		Claw thickness	4.86-4.94	4.60
	Gearshift drum O.D.		33.950-33.975	33.93

#### TORQUE VALUE

Shift drum bolt 12 Nm

#### TOOLS

Special  
Universal bearing puller

Common  
Inner driver  
Attachment, 20 mm  
Driver  
Attachment, 37 x 40 mm  
Pilot, 17 mm

#### TROUBLESHOOTING

##### Hard to shift

- Incorrect clutch adjustment
- Bent gearshift fork
- Worn gear dogs
- Damaged gearshift drum groove
- Damaged guide pin

##### Transmission Jumps out of gear

- Worn gear dogs
- Bent gearshift fork
- Damaged gearshift drum stopper

##### Engine noise

- Worn main Journal bearing
- Worn crankpin bearing
- Worn piston pin
- Worn piston pin bore

##### Transmission noise

- Worn gears
- Damaged or worn mainshaft and/or countershaft

**TRANSMISSION / CRANKSHAFT / KICK STARTER****CRANKCASE SEPARATION**

Remove the required parts.

Remove the cam chain.

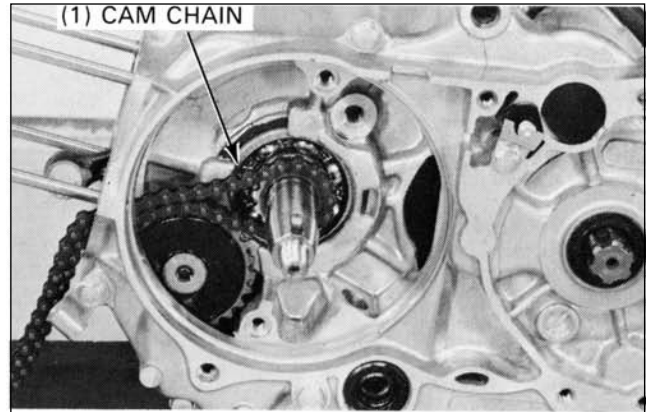

Loosen the screw (1), remove the rubber cap (2), gearshift drum bolt (3) and moving contact (4).

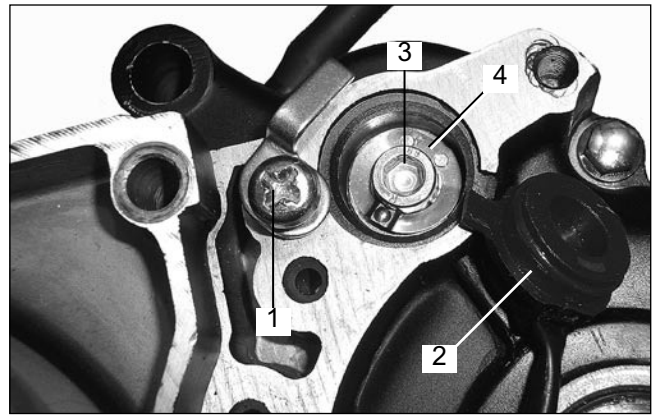

Remove the crankcase bolts.

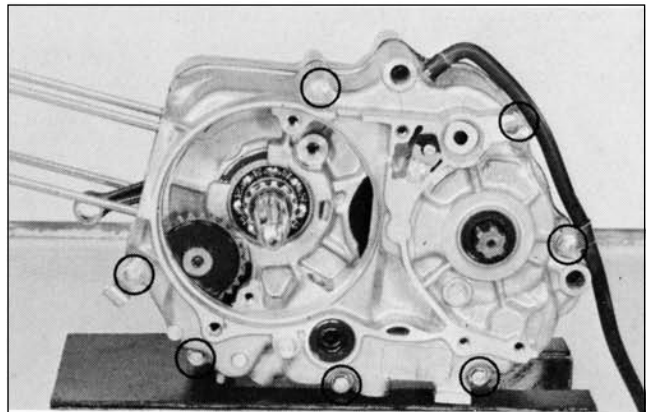

Place the crankcase on the work bench.

Pry out the circlip on the kick starter spindle.

Remove the kick return spring and spring retainer.

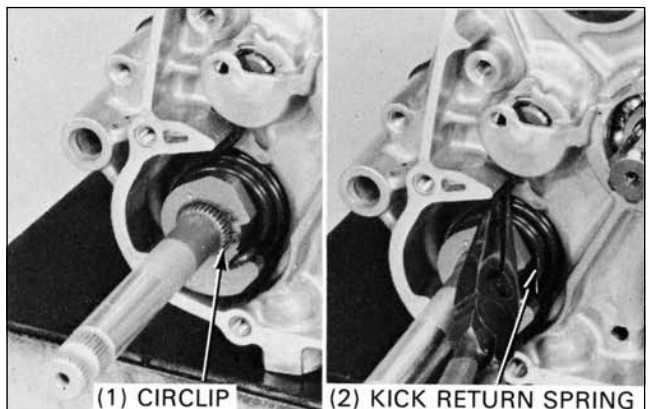

**TRANSMISSION / CRANKSHAFT / KICK STARTER**

Separate the right crankcase from the left crankcase.

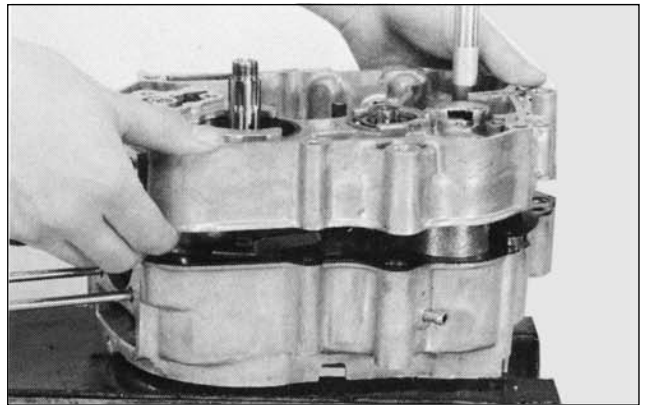

Remove the gasket and dowel pins.

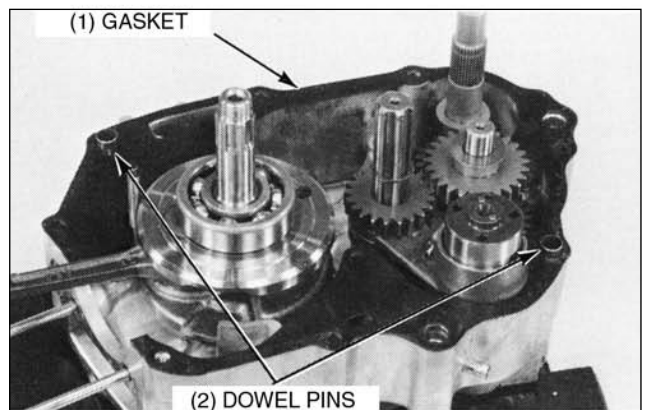
**CRANKSHAFT INSPECTION**

Remove the crankshaft from the left crankcase.

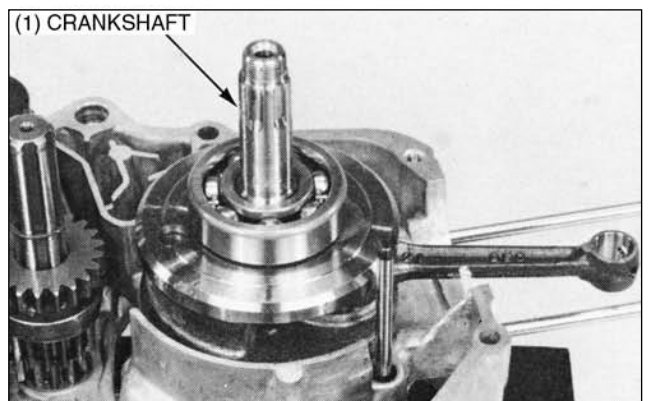

Measure the connecting rod big end side clearance.

**SERVICE LIMIT: 0.60 mm (0.024 in)**

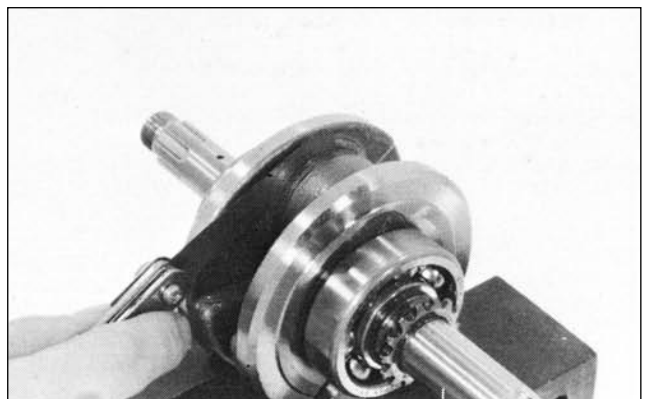

**TRANSMISSION / CRANKSHAFT / KICK STARTER**

Measure the connecting rod big end radial clearance at two different points across from each other as shown.

**SERVICE LIMIT: 0.05 mm (0.002 in)**

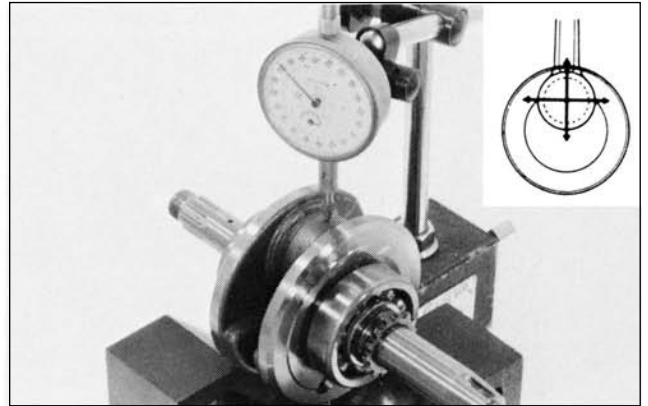

Place the crankshaft on a stand or V-blocks and measure the runout using a dial indicator.

**SERVICE LIMIT: 0.10 mm (0.004 in)**

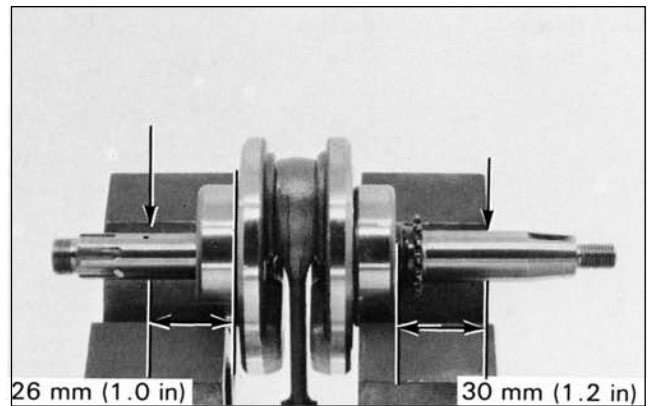

Turn the outer race of the crankshaft bearing with finger. The outer race should turn smoothly and quietly. Also check that the bearing inner race fits tightly on the crankshaft. Replace the crankshaft bearing if the outer race does not turn smoothly, quietly, or if it fits loosely on the crankshaft.

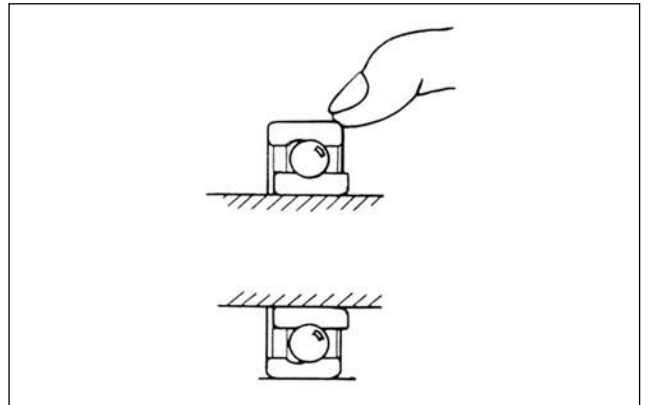

**TIMING SPROCKET REPLACEMENT**

Carefully inspect the timing sprocket teeth for wear or damage. If necessary, remove the damaged sprocket from the crankshaft.

Align any center between the teeth of a new sprocket with the key way on the crankshaft and drive the sprocket onto the shaft.

**TOOLS:**  
Inner driver  
Attachment, 20 mm

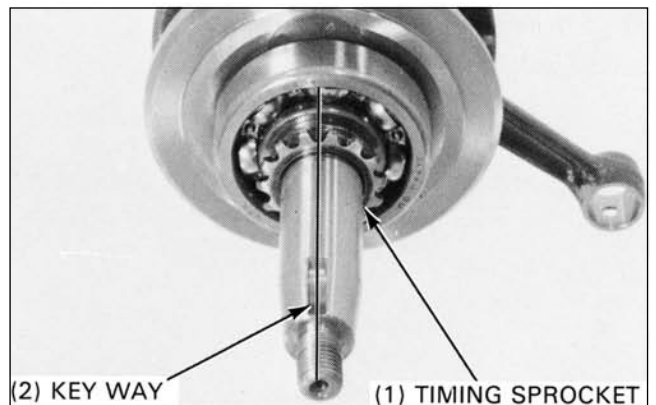

**TRANSMISSION / CRANKSHAFT / KICK STARTER****KICK STARTER****DISASSEMBLY/ REASSEMBLY**

Remove the kick starter from the left crankcase.

Remove the circlips and remove the kick starter pinion and friction spring.

Check the disassembled parts for damage and excessive wear and replace them if necessary.

Assemble the kick starter as shown.

Install the kick starter assembly into the left crankcase by aligning the friction spring with the groove in the crankcase as shown.

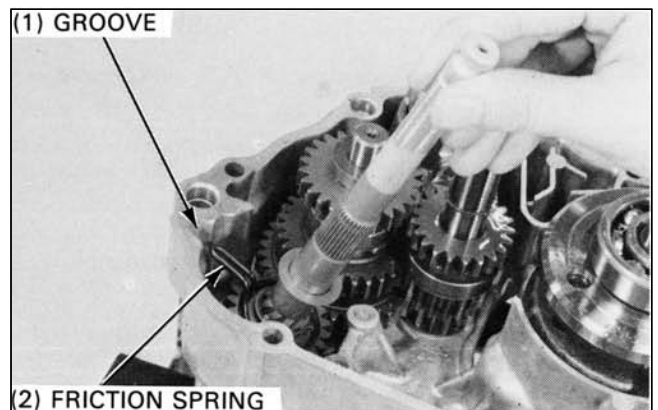
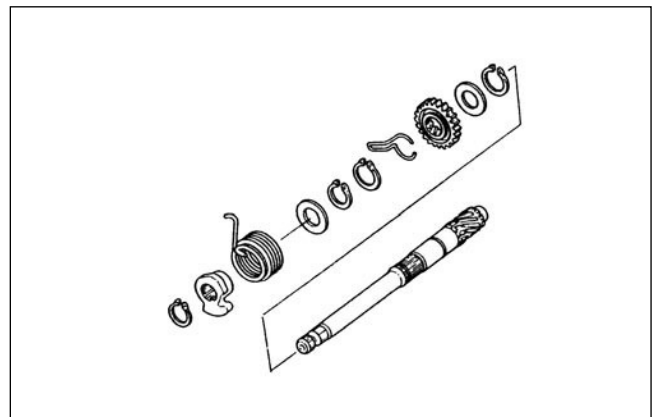
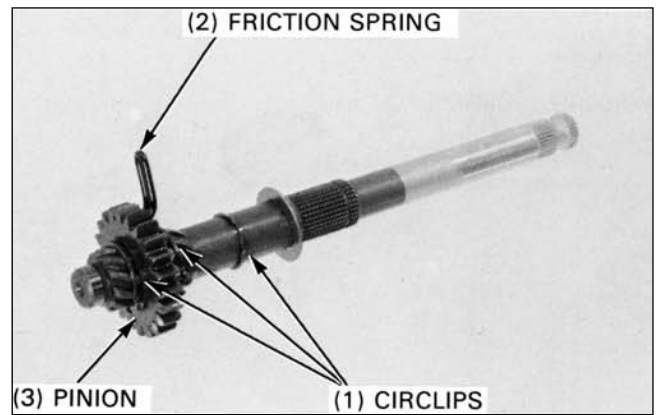
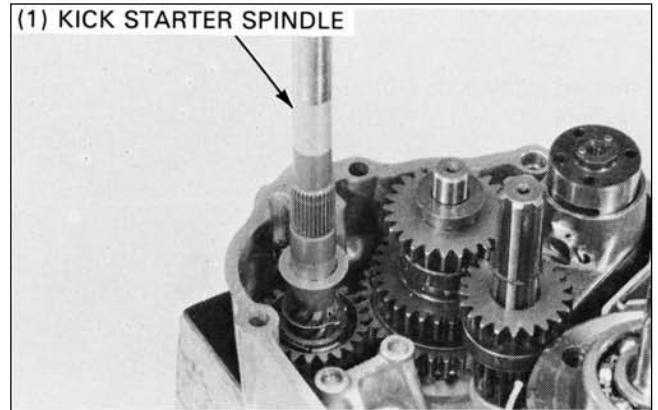



**TRANSMISSION / CRANKSHAFT / KICK STARTER**

**TRANSMISSION DISASSEMBLY**

Separate crankcase.

Remove the kick starter.

Remove the transmission and shift drum as an assembly.

Separate the shift drum assembly from the transmission gears.

Remove the gears from the mainshaft and countershaft.

**INSPECTION**

Measure the mainshaft and countershaft O.D.

**SERVICE LIMITS:**

**M2: 16.95 mm (0.667 in)**

**C1: 16.94 mm (0.667 in)**

Check each gear for wear or damage.

Measure the gear I.D.

**SERVICE LIMITS:**

**M2: 17.10 mm (0.673 in)**

**C1: 20.10 mm (0.791 in)**

**C3: 17.10 mm (0.673 in)**

Measure the I.D. and O.D. of the C1 gear bushing.

**SERVICE LIMITS:**

**I.D.: 17.08 mm (0.672 in)**

**O.D.: 19.93 mm (0.785 in)**

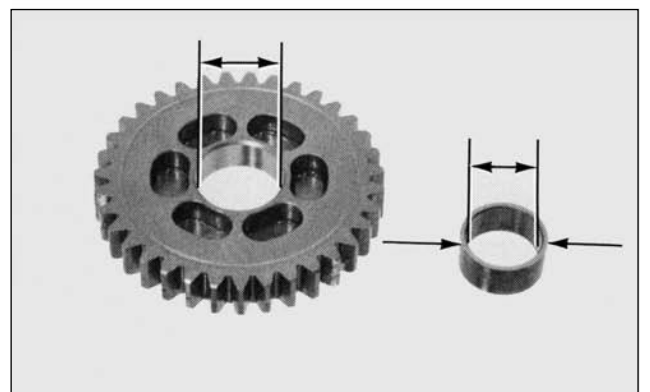
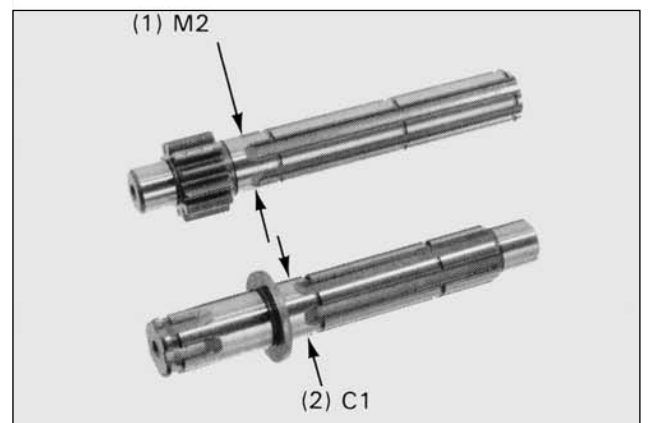
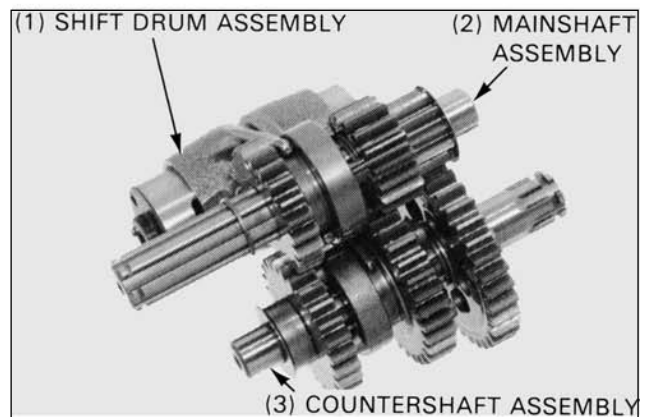
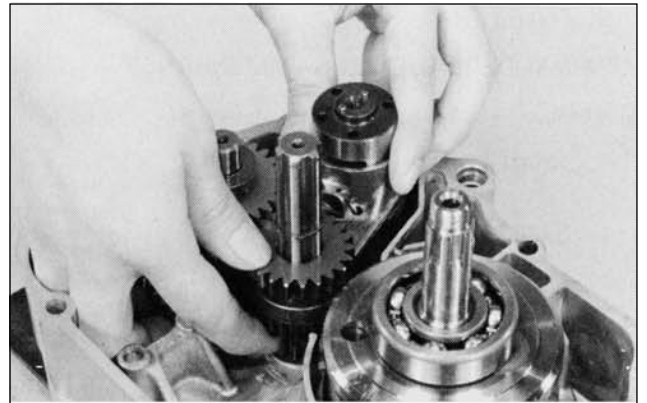

**TRANSMISSION / CRANKSHAFT / KICK STARTER**

**SHIFT DRUM/ FORK DISASSEMBLY**

Pull out the guide pin clips and the shift fork guide pins.

Remove the shift forks from the shift drum.

**NOTE**

Mark the right and left shift forks to ensure correct assembly.

Straighten the tab and remove the neutral switch rotor.

**INSPECTION**

Check the gearshift drum for wear or damage.

Measure the gearshift drum O.D.

**SERVICE LIMIT: 33.93 mm (1.336 in)**

Check the guide pins and shift forks for wear or damage.

Measure the shift fork I.D.

**SERVICE LIMIT: 34.14 mm (1.344 in)**

Measure the shift fork claw thickness.

**SERVICE LIMIT: 4.60 mm (0.181 in)**

**TRANSMISSION BEARING INSPECTION**

Turn the races of each bearing with your finger.  
The bearing should turn smoothly and quietly.  
Also check that the bearing outer race fits tightly in the crankcase.

Remove and discard the bearing if the races do not turn smoothly, quietly, or if they fit loosely in the crankcase.

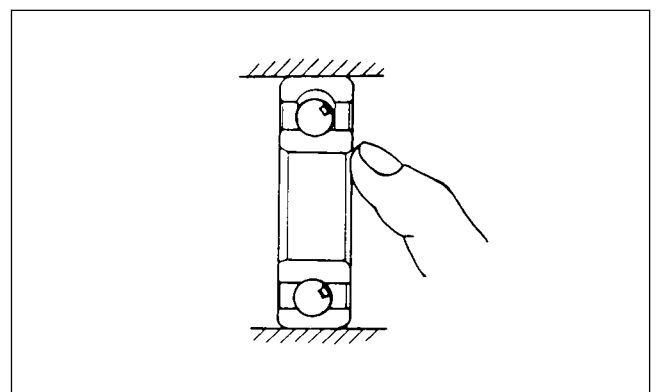
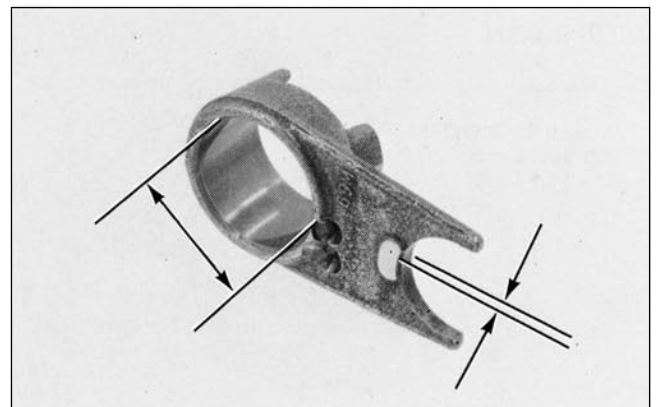
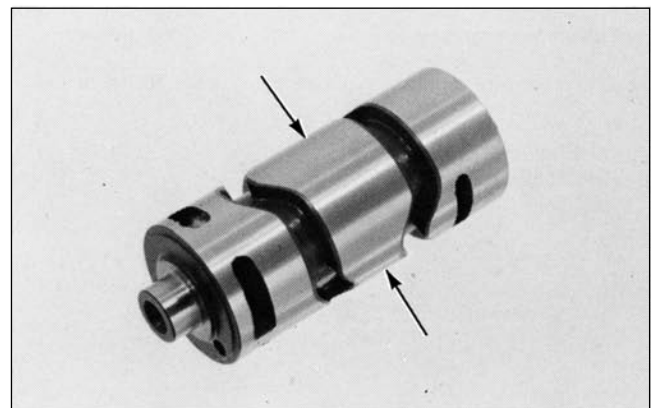
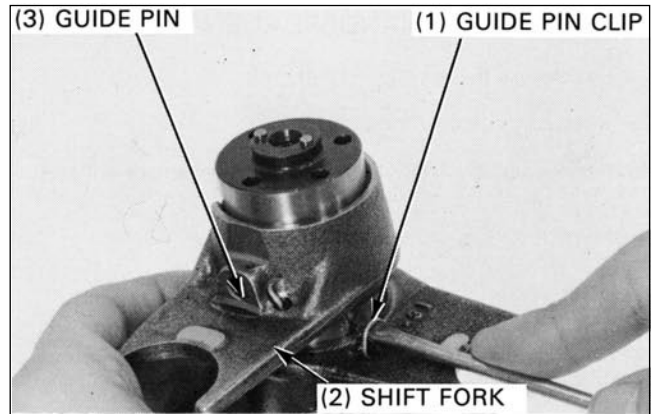

**TRANSMISSION / CRANKSHAFT / KICK STARTER**

**CRANKCASE BEARING REPLACEMENT**

**Right Crankcase**

Drive out the mainshaft bearing from the outside.

Drive a new bearing into the place.

**TOOLS:**

Driver

Attachment, 37 x 40 mm

Pilot, 17 mm

**Left Crankcase**

Remove the oil seal and drive out the countershaft bearing.

Drive a new bearing into the left crankcase.

**TOOLS:**

Driver

Attachment, 37 x 40 mm

Pilot, 17 mm

Apply grease to the lip of a new oil seal and install it in the crankcase.

**NOTE**

Align the top of the oil seal with the crankcase. Do not allow the seal to contact the bearing.

**TRANSMISSION ASSEMBLY**

Install the right and left shift forks onto the gearshift drum.

Insert the guide pins and guide pin clips.

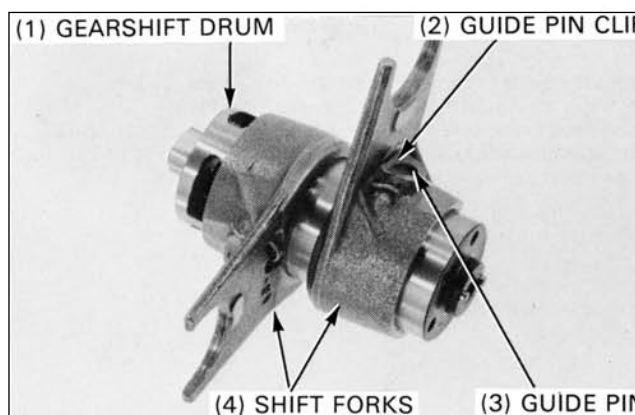
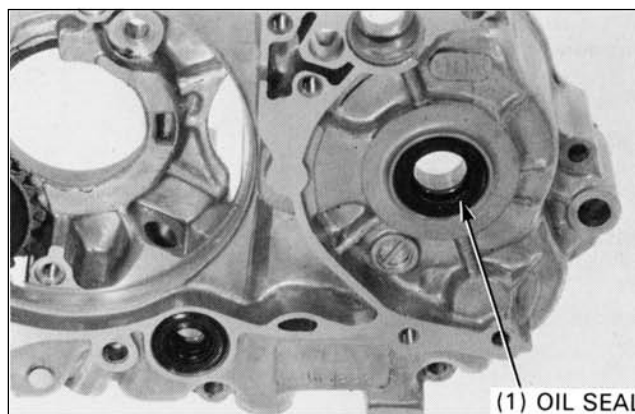
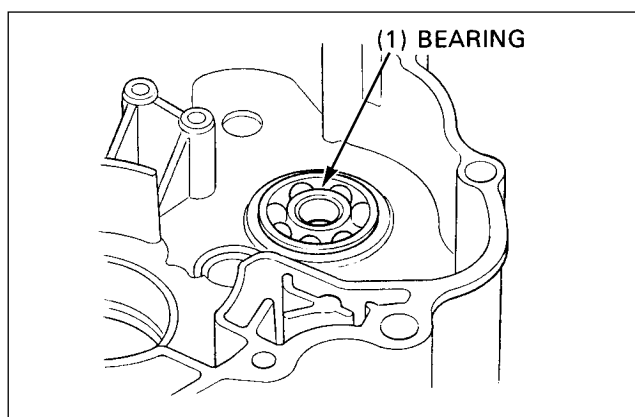
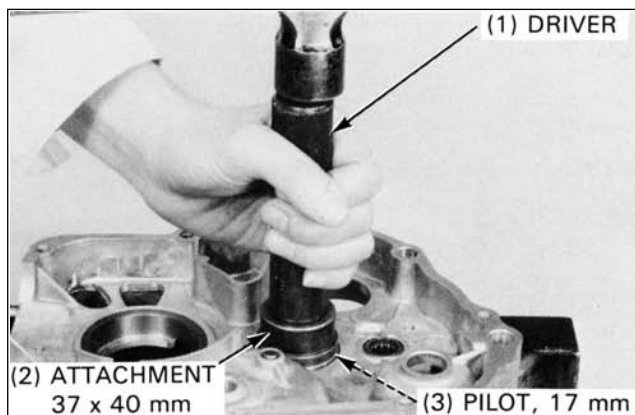

**TRANSMISSION / CRANKSHAFT / KICK STARTER**

Install the neutral switch rotor into the shift drum and bend the tab to lock the switch rotor.

Coat the gears and shafts with clean engine oil.

Assemble the countershaft and mainshaft.

**NOTE**

Set the circlip in the groove properly.

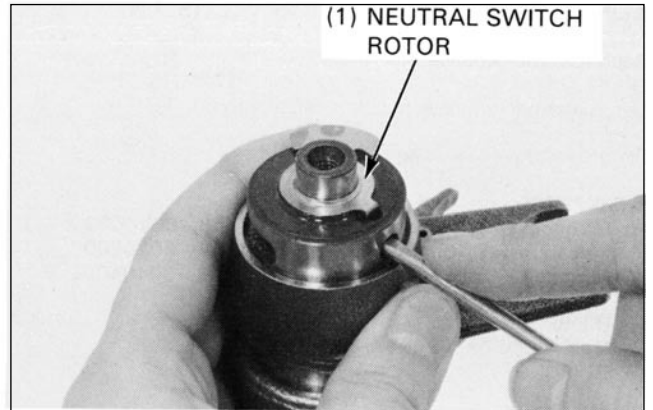

- 1 23 Teeth
- 2 26 Teeth
- 3 29 Teeth
- 4 34 Teeth
- 5 Countershaft
  
- 6 12 Teeth
- 7 Mainschaft
- 8 17 Teeth
- 9 21 Teeth
- 10 24 Teeth

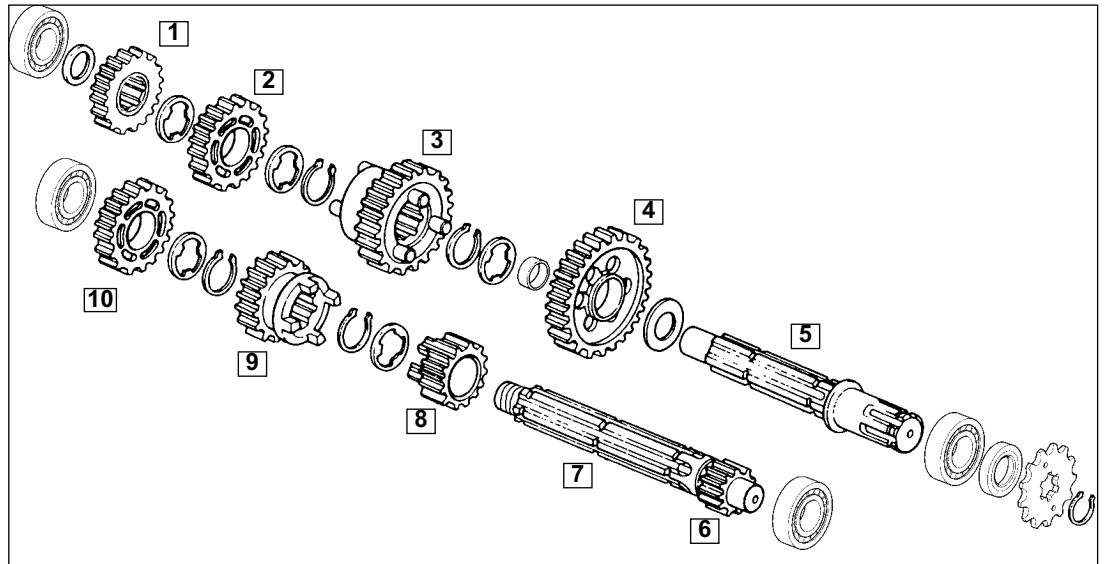

Assemble the shift drum, countershaft and mainshaft assemblies.

Install the transmission assembly in the left crankcase as a set.

Turn the mainshaft and make sure that the transmission works properly.

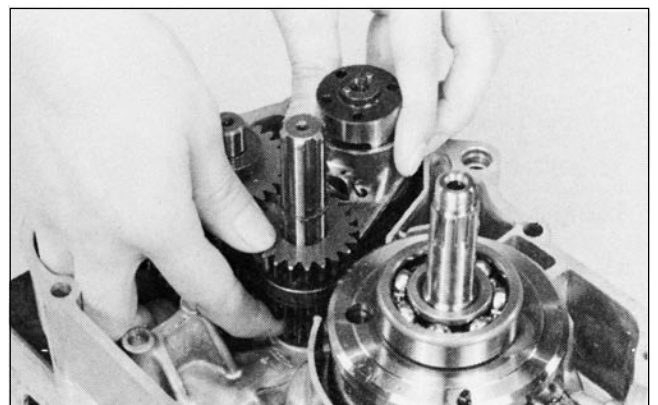

**TRANSMISSION / CRANKSHAFT / KICK STARTER**

**CRANKCASE ASSEMBLY**

Install the kick starter.

Install the crankshaft.

Install the dowel pins and a new gasket.

Install the right crankcase on the left crankcase.

Tighten the crankcase bolts securely in a crisscross pattern in two or more steps.

Install the moving contact (1) and shift drum bolt (2).

Tighten the bolt.

**TORQUE: 12 Nm**

Check the O-ring (3) and replace if necessary.

Install the neutral switch (4) carefully and fix with the plate and screw (5).

**TORQUE: 10 Nm**

Install the kick starter spring and spring retainer onto the kick spindle.

Hook the return spring to the right crankcase as shown.

Install the circlip onto the kick spindle.

Reassemble the removed parts in the reverse order of removal.

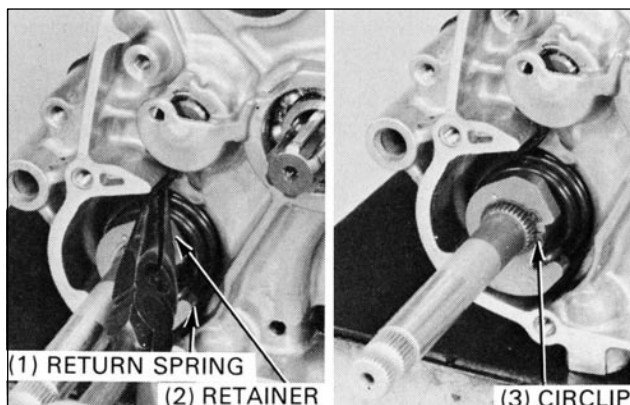
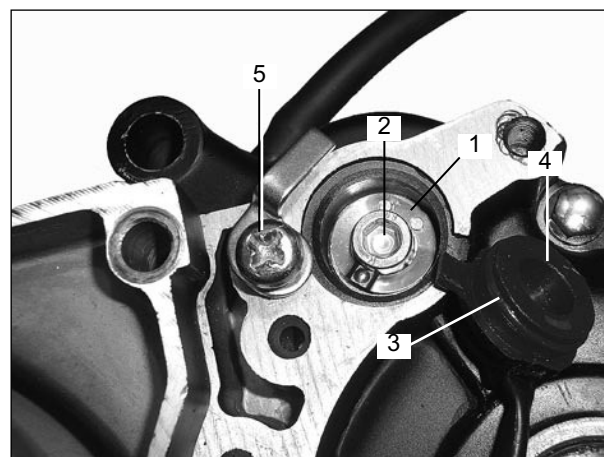
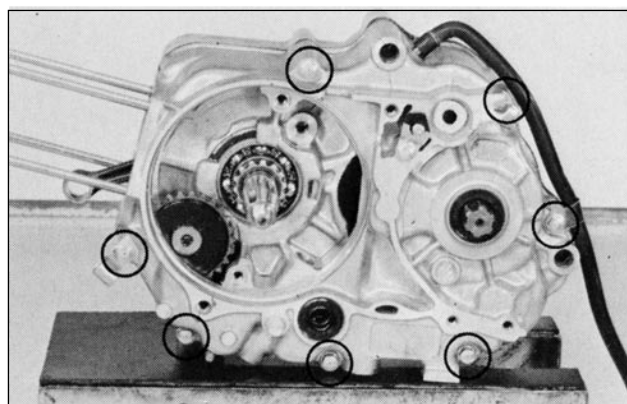
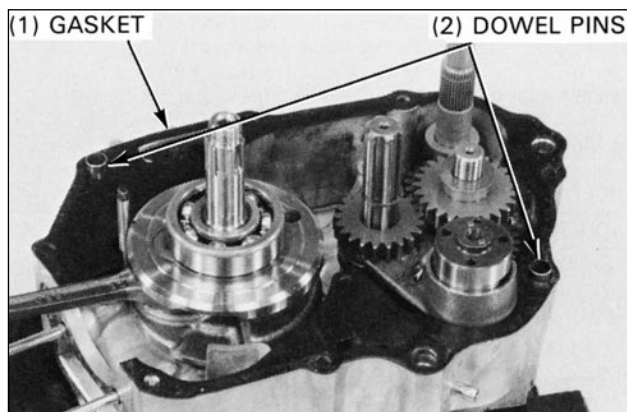

**ELECTRICAL SYSTEM**

**FUSE**

**CAUTION**

Never install a fuse with a larger rating, doing so could destroy the entire electrical system.

The fuse is located behind the battery upper cover (3).

**Replace fuse**

- Unscrew four screws (1) on the left and right side of the lower cover (4) and pull it off downward.
- Unscrew three screws (2) and lift off the upper cover (3) to the left side.
- Open the fuse case cap (5).
- A faulty or blown fuse (6) must be replaced by a new one with a rating of 15 A.
- Install to take place in reverse order.

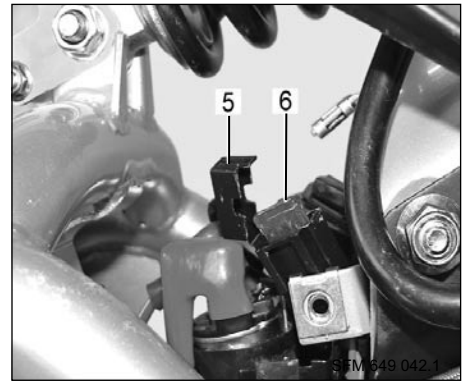
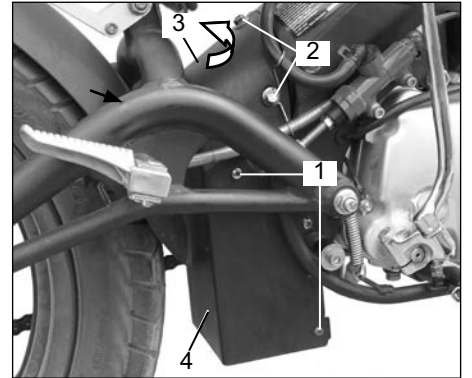

## ELECTRICAL SYSTEM

### BATTERY



#### WARNING

Always wear safety glasses.  
Keep children away from acids and batteries.



#### EXPLOSION DANGER

A battery being charged produces a highly explosive gas, which is why fire, sparks, naked flames and smoking are prohibited.



#### FIRE HAZARD

Avoid generating sparks and electrostatic discharges when handling cables and electrical devices.

Avoid short circuits.



#### DANGER - CAUSTIC ACTION

Battery acid is highly caustic, so always wear safety gloves and glasses.

Do not tilt the battery as acid can leak from the ventilation openings.



#### FIRST AID

If acid comes into contact with an eye, immediately flush the eye for several minutes with fresh water. Then immediately visit / call a doctor.

Acid on the skin or clothing must immediately be neutralised using acid converter or soap suds, and the spots must be flushed with plenty of water.

If acid is swallowed, immediately visit / call a doctor.



#### CAUTION

Do not expose batteries to direct sunlight. Discharged batteries can freeze, so they must be stored in a place where the temperature remains above 0 °C.

Professional maintenance, charging and storage will increase the lifespan of the battery and are a condition for the honouring of guarantee claims.



#### DISPOSAL

Take a dead battery to a collection point. Never dispose of one with household refuse.

### Charging the battery

After a long lay-up (3-4 months), charge the battery. The charging current (in amperes) must not exceed 1/10<sup>th</sup> of the battery capacity (Ah). The battery must not be fast-charged. The battery may only be charged using a special charger approved for MF batteries.

### Maintenance

Although the battery is maintenance-free. Never leave the battery discharged. Keep the battery clean and dry and make sure that the connection terminals are firmly seated.



#### CAUTION

The battery may only be connected or disconnected while the ignition is inactive.

First disconnect the minus terminal (black cable). When installing the battery, first connect the plus terminal (red cable). The battery is maintenance-free. Do not try to open it.

**ELECTRICAL SYSTEM**

**Commissioning maintenance-free batteries (MF)**

The steps described below must be strictly observed in order to guarantee the long lifespan of the battery.

Work steps:

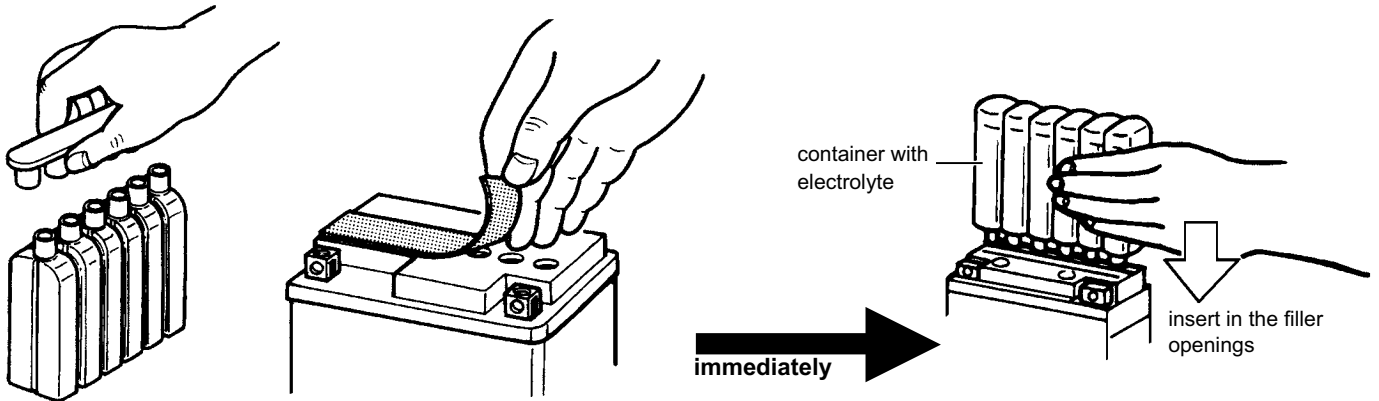

Pull the shut-off plug of the battery from the acid pack and remove the aluminium foil used to seal the battery (once the aluminium foil has been removed, the battery must be **filled immediately!**)

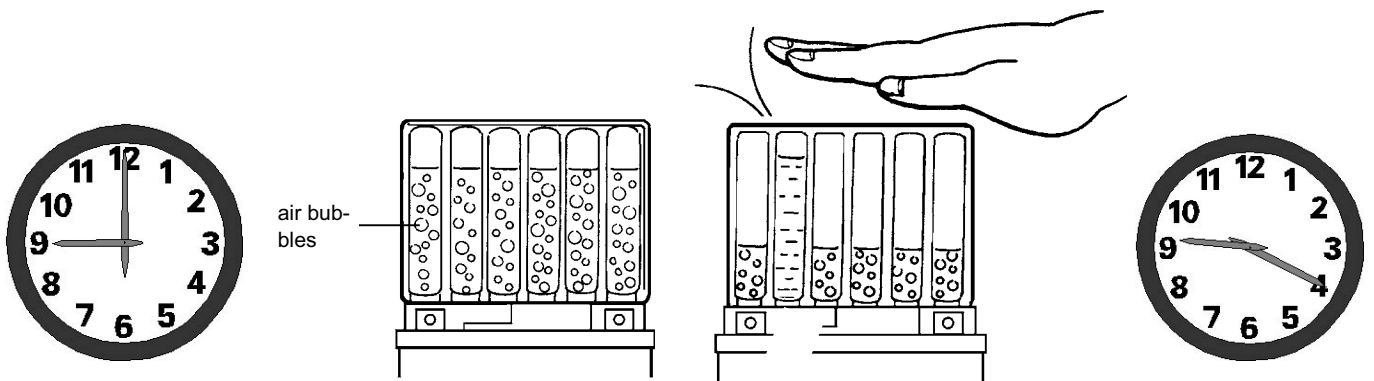

Insert the acid pack into the filler opening of the battery and allow the acid to run into the battery (keep the acid pack in this position for at least **20 minutes**).

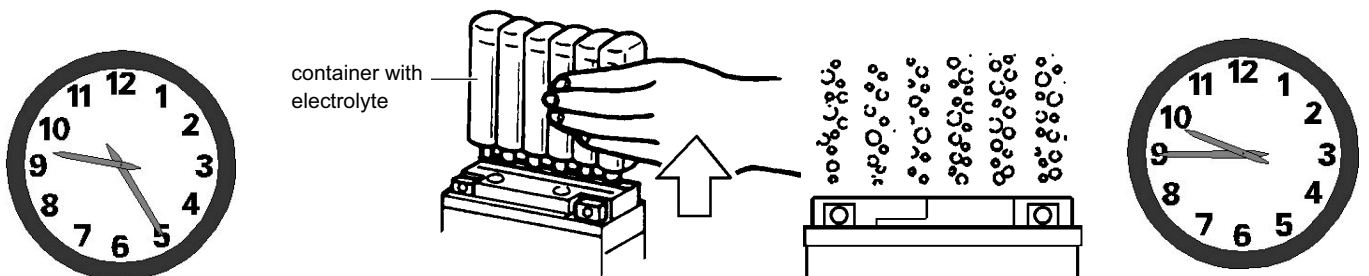

Remove the **acid pack from the battery** and allow the battery to de-gas for another 20 minutes.



**ELECTRICAL SYSTEM**

**Commissioning maintenance-free batteries (MF)**

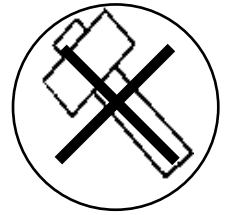
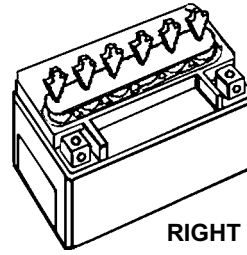
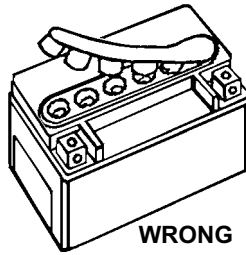
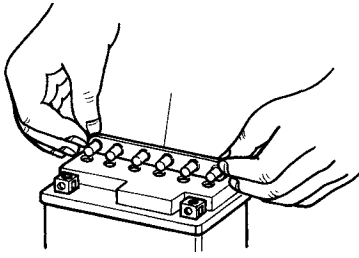

Close the battery using **only the fingers**, so that all plugs are **simultaneously** pressed into the battery.

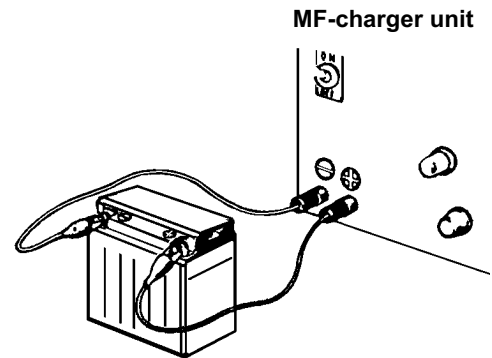
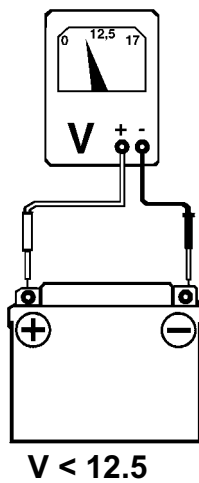
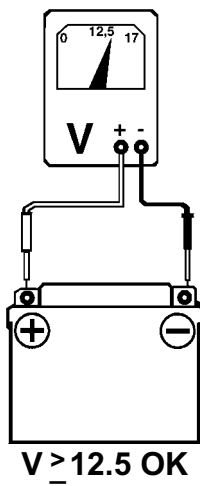

Now check the battery voltage using a volt meter; if the voltage is **lower than 12.5 volt**, the battery must **be recharged** by means of an MF charger unit.

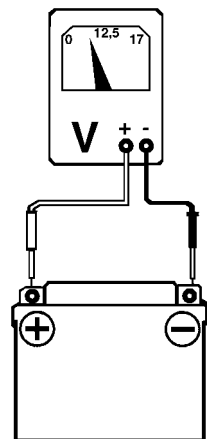
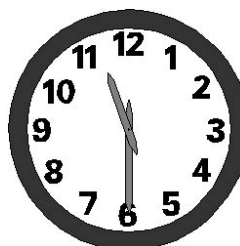
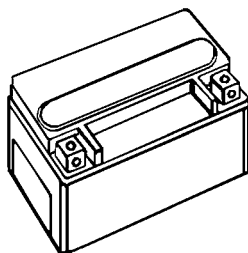
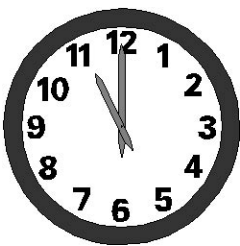

After charging, wait at least **30 minutes** and again check the battery using the volt meter. If the voltage is still **lower than 12.5 volt**, the battery must **be recharged**.

- If the battery voltage after the second charging cycle is still lower than 12.5 volt, the battery must be replaced.
- If the motorcycle remains unused for a longer period, the battery must be **checked or recharged every month**.
- To charge a maintenance-free battery you must use a suitable charger unit. The recharge may not exceed a **max. charging current of 1/10th** of the battery capacity.

**ELECTRICAL SYSTEM**

**Cockpit**

**Speedometer**

- 1 MPH - odometer
- 2 DST - total distance

**Instrument lights**

- 3 Right and left direction indicator ↔ green
- 4 Change-over gear Neutral (N) N green

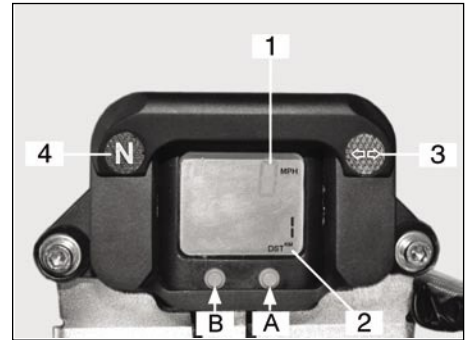

**Speedometer set-up**

Button A press once  
set-up from odometer  
(DST) to clock (CLK)

or

Button A press once  
set-up from clock (CLK)  
to odometer (DST)

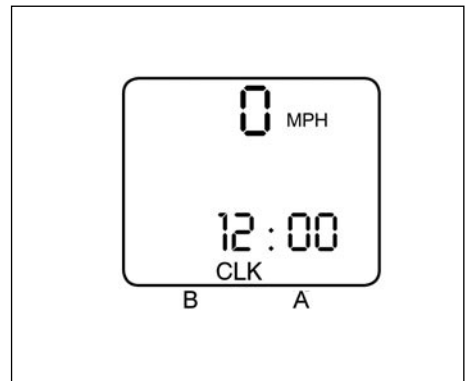
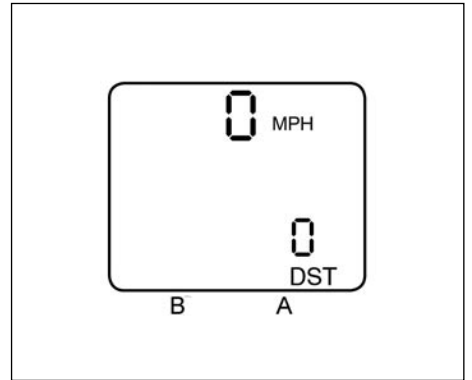

**Speedometer time adjustment**

Button B press once  
the clock (CLK) appears the time can be set.

Button B press twice  
the hour signal is flashing set the hours by pressing  
button A.

Button B press thrice  
the minute signal is flashing set the minutes by press-  
ing button A.

Button B press four times  
the time is set and ( : ) is flashing.

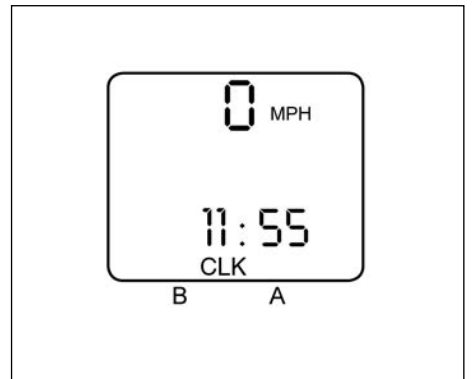

**ELECTRICAL SYSTEM**

**Speedometer battery change**

**NOTE**

If there is no reading on the display or very poor visibility change the batteries. Always replace both batteries.

Remove the speedometer for battery change.

- Remove the screws (1) and take off the speedometer.
  
- Remove the screws (2) and (3) and take off the cover (4).
  
- Remove the batteries (5) and use new batteries, type AG 13.
- Set-in the batteries with the plus terminal showing upwards.
- Insert the O-rings (6) and close the cover (4) properly.

**NOTE**

After battery change set-up the time again. The total distance is set on zero.



**DISPOSAL**

Take a dead battery to a collection point. Never dispose of one with household refuse.

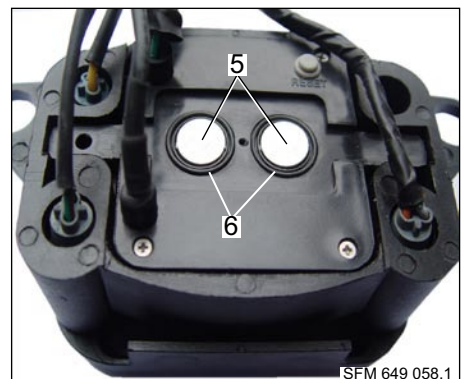
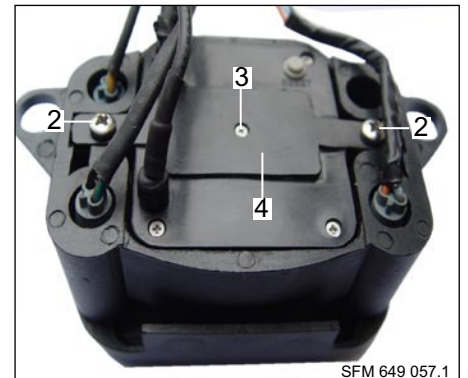



**ELECTRICAL SYSTEM****Indicator****NOTE**

The indicator glass (1) must be removed to replace the light bulb.

Do not touch the bulbs with bare fingers. Use a clean, dry cloth for installation and removal.

- Unscrew the scREW (2)
- Remove the glass (1).
- Unlock and remove the bulb (3).
- Installation to take place in reverse order.

**Indicator bulbs: 12 V/21W**

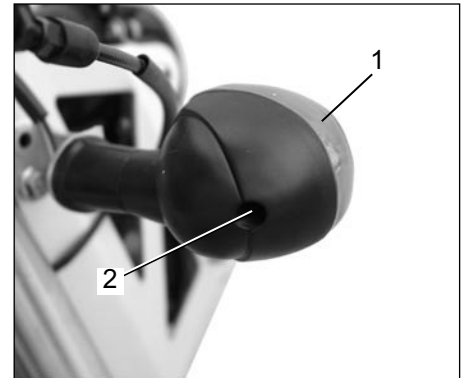

## ELECTRICAL SYSTEM

### Adjusting the headlamps

#### WARNING

Do not run the engine in an enclosed space (risk of asphyxiation).

Position the motorcycle on a level floor 5 m (measured from the headlamp) from a light coloured wall with a rider seated on the motorcycle and the tires filled at the correct pressure.

- Measure the distance from the floor to the centre of the headlamp and mark the height on the wall with a cross. Draw a second cross 12 cm beneath the first cross.
- Start the motorcycle and run the engine.
- Activate the dipped beam.
- Use the adjusting screw (1 and 2) on both sides to adjust the angle of the asymmetrically illuminated surface area of the road top.
- Release screws (1) and (2), adjust and tighten up.

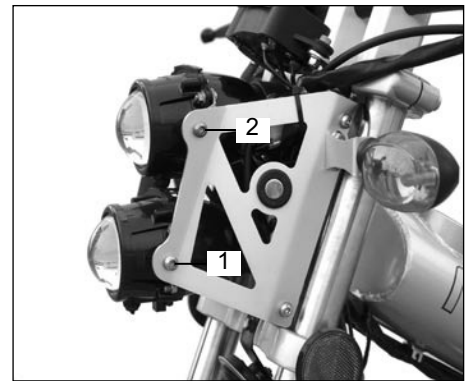
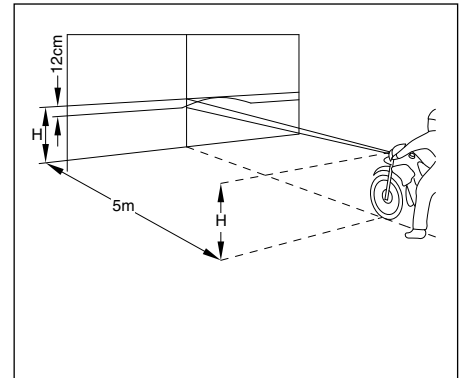

**IGNITION SYSTEM**

**SCHEMATIC**

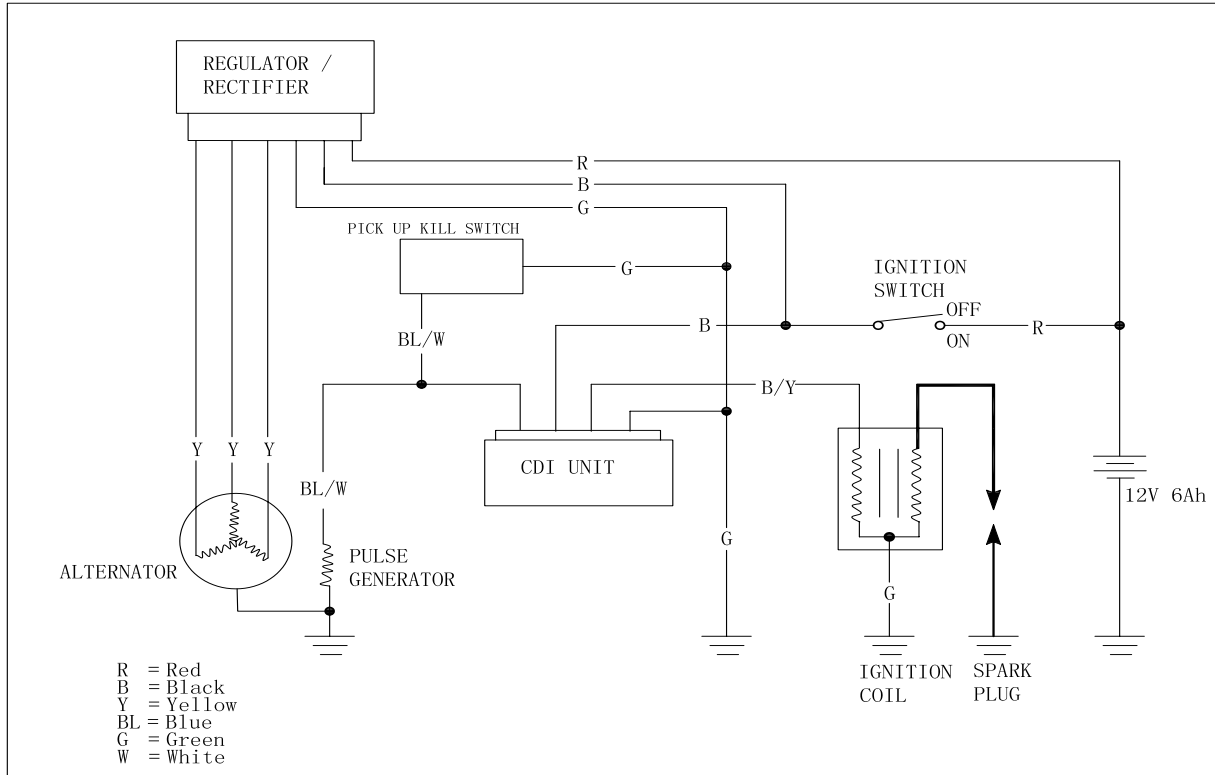

## IGNITION SYSTEM

### SERVICE INFORMATION

#### GENERAL

Ignition timing does not normally need to be adjusted since the CDI (Capacitive Discharge Ignition) unit is factory pre-set. If the ignition timing is incorrect, check the CDI unit, pulse generator and alternator and replace the part(s) as required.

SPECIFICATIONS	
Ignition system	CDI unit
Ignition timing	15 ° before TDC at 2.000 rpm 30 ° before TDC at 3.500 rpm
Electrode gap	0,7 mm - 0,8 mm
Pulse generator resistance (pick-up)	circa 125 Ω (bl/w - ground)

### TROUBLESHOOTING

No spark at plug		
1. Exchange the spark plug with known-good spark plug and try spark test.	GOOD SPARK →	Faulty original spark plug
↓ WEAK OR NO SPARK		
2. Check for loose CDI unit connector	ABNORMAL →	Loose connector
↓ NORMAL		
3. Disconnect the CDI unit connector from the CDI unit and test for system components at CDI unit 5P connector	ABNORMAL →	3-1. Check the individual component(s)
↓ NORMAL	↓ NORMAL	Open or short circuit in wire harness Loose connector(s)
	↓ ABNORMAL	Faulty ignition coil Faulty pulse generator Faulty exciter coil
4. Check the CDI unit itself using CDI unit tester	ABNORMAL →	Faulty CDI unit
↓ NORMAL		
5. Check the ignition coil using CDI unit tester	ABNORMAL →	Faulty ignition coil
↓ NORMAL		
→		Faulty flywheel Stator and / or pulse generator not installed properly

#### Engine starts but runs poorly

- |   |  |
|---|--|
| <ol style="list-style-type: none"> <li>1. Ignition primary circuit<br/>Faulty ignition coil<br/>Loose or bare wire or connector<br/>Faulty ignition switch connection</li> <li>2. Ignition secondary circuit<br/>Faulty ignition coil<br/>Faulty spark plug<br/>Faulty spark plug wire<br/>Plug cap installed improperly</li> </ol> | <ol style="list-style-type: none"> <li>3. Improper ignition timing<br/>Faulty pulse generator<br/>Stator not installed properly<br/>Faulty CDI unit</li> </ol> |
|---|--|



**IGNITION SYSTEM**

**CDI UNIT**

**Removal**

Remove the battery cover and the battery.

Disconnect the connector and remove the CDI unit.

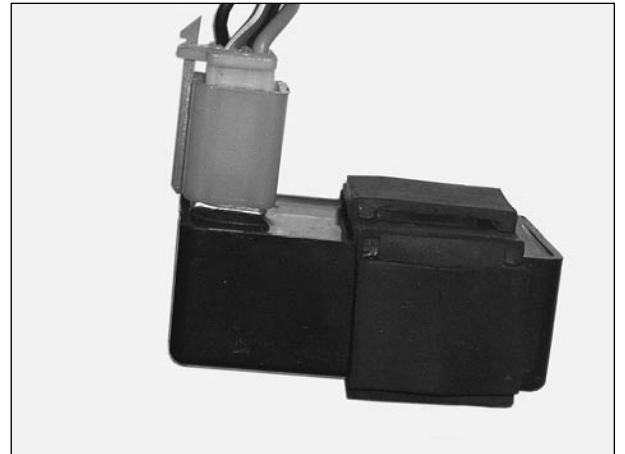

**Inspection**

System inspection

Disconnect the 4- pole connector from the CDI unit and test the wires at the harness- side connector according to the table below:

Item	Measure at:	Standard
Ignition coil (primary)	Black/Yellow - Green	circa 1 $\Omega$
Signal generator coil (pick-up)	Blue/white - green	circa 125 $\Omega$
Ignition switch	Black - green	circa 12V in ignition position ON and 0V in ignition position OFF.
Ground	Green - frame ground	There should be continuity.

If any one item does not meet the standard, test the individual component and replace it or repair open short circuit in wire or loose connector as required.

## IGNITION SYSTEM

### IGNITION COIL

#### REMOVAL

Disconnect the spark plug cap from the spark plug.  
Remove the mounting nuts and ignition coil.

#### IGNITION COIL (checking with the pocket tester)

A pocket tester or an ohm meter may be used, instead of the electro tester. In either case, the ignition coil is to be checked for continuity in both primary and secondary windings. Exact ohm readings are not necessary, but, if the windings are in sound condition, their continuity should be close to the specified values.

**Tool: Pocket tester**

**Tester knob indication: x 1  $\Omega$  range**

#### PRIMARY COIL INSPECTION

Measure the resistance between the terminals.

**RESISTANCE: circa 1  $\Omega$  at 20°C**

Replace the ignition coil if the resistance is out of specification.

#### SECONDARY COIL INSPECTION

Measure the secondary coil resistance with the cap installed.

**RESISTANCE: circa 10 k $\Omega$  at 20°C**

If the resistance is out of specification, remove the spark plug cap from the wire and remeasure.

**RESISTANCE: circa 5 k $\Omega$  at 20°C**

If the resistance is within the specified range, replace the spark plug cap.

If the resistance is out of specification, replace the ignition

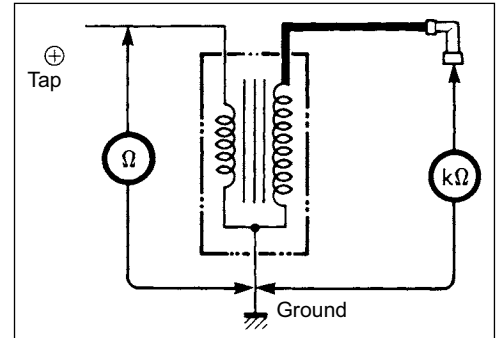

## IGNITION SYSTEM

### ALTERNATOR

(Exciter coil)

Disconnect the alternator wire connector.

Measure the resistance between the three Yellow wires.

**RESISTANCE: circa 1.3  $\Omega$**

If the resistance is out of specification replace the alternator.

### PULSE GENERATOR (PICK-UP)

Remove the battery cover and the battery.

Disconnect the alternator pick-up connector and measure the resistance between the blue/white wire terminal and ground.

**RESISTANCE: circa 125  $\Omega$**

If the resistance is out of the specification, replace the alternator.

### IGNITION TIMING INSPECTION

#### NOTE

The Capacitive Discharge Ignition (CDI) system is factory pre-set and does not require adjustment. To inspect the function of the CDI components, ignition timing inspection procedures are given here.

Remove the left crankcase cover.  
Connect a tachometer and timing light.  
Start the engine and allow it to idle.

**IDLE SPEED: 1,800 +/- 200 rpm**

Inspect the ignition timing

Timing is correct, if the "F" mark on the flywheel is aligned with the index mark on the left crankcase at idle.

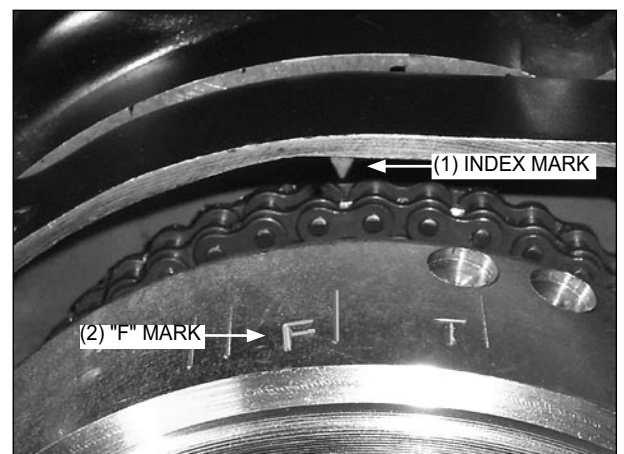

**WIRING DIAGRAM**

**4-GEAR ENGINE**

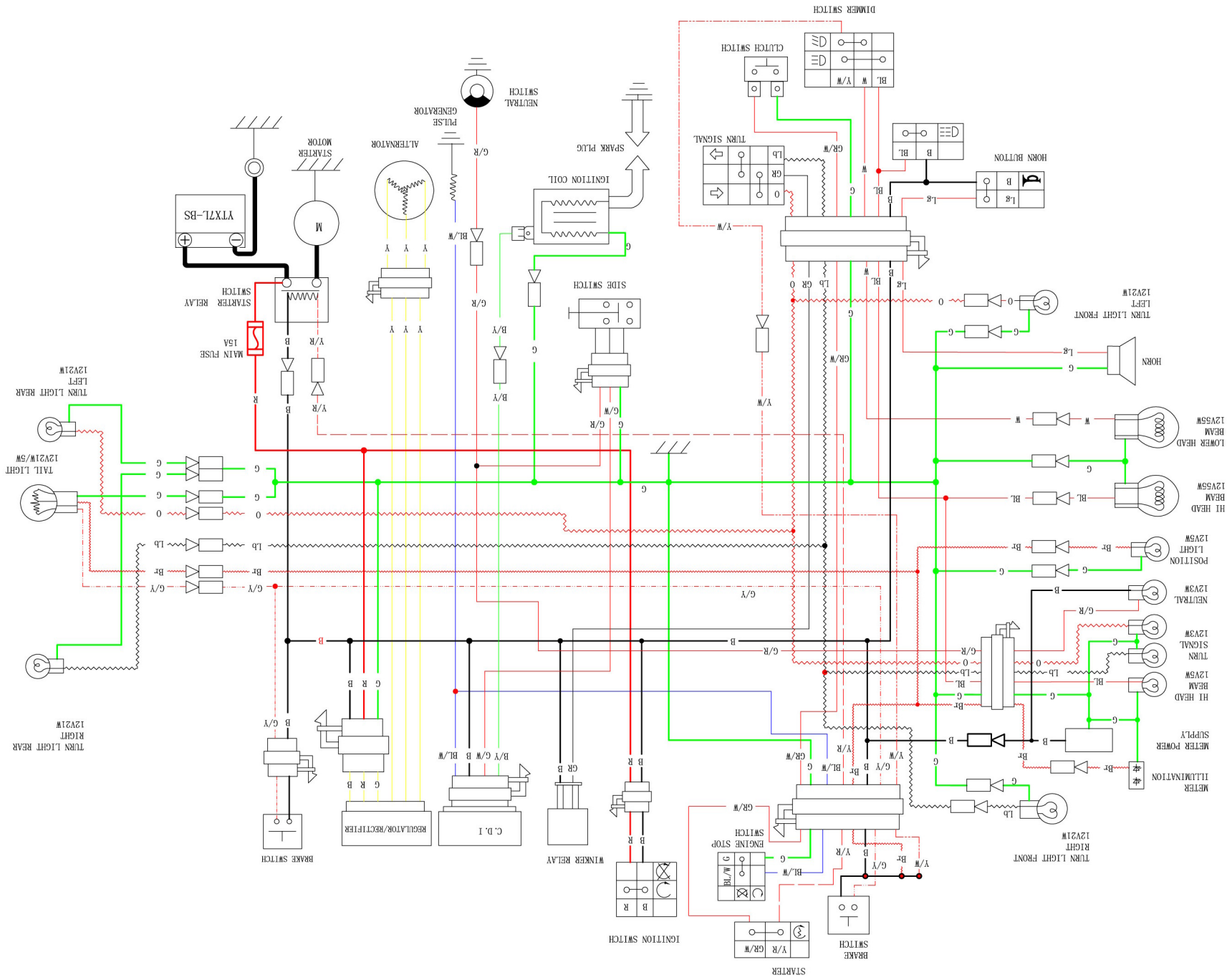

## TROUBLESHOOTING

Engine		
Complaint	Symptom and possible causes	Remedy
<b>Engine will not start or is hard to start.</b>	<b>Compression too low</b>	
	Worn cylinder	Rebore or replace
	Worn piston ring	Replace.
	Worn valve guide or improper valve seating	Repair or replace
	Loose spark plug	Tighten.
	Broken, cracked or damaged piston	Replace
	Slow cranking starter motor	See electrical section
	Mistimed valves	Adjust
	Tappet clearance out of adjustment	Adjust
	<b>Spark plug not sparking</b>	
	Damaged spark plug	Replace
	Damaged spark plug cap	Replace
	Fouled spark plug	Clean or replace
	Wet spark plug	Clean and dry or replace
	Defective ignition coil	Replace
	Open or short in high-tension cord	Replace
	Defective pick-up coil or CDI unit	Replace
	<b>No fuel reaching a carburetor</b>	
Clogged or defective fuel valve	Clean or replace	
Defective carburetor needle valve	Replace with carburetor needle valve seat	
Clogged fuel hose	Clean or replace	
Clogged fuel filter	Clean or replace	
<b>Engine stalls easily</b>	Fouled spark plug	Clean or replace
	Defective pick-up coil or CDI unit	Replace
	Clogged fuel hose	Clean
	Clogged carburetor jet	Clean
	Tappet clearance out of adjustment	Adjust
<b>Engine is noisy</b>	<b>Excessive valve chatter</b>	
	Excessive tappet clearance	Adjust
	Weak or broken valve spring	Replace
	Worn cam surface	Replace
	Worn or burnt camshaft journal	Replace camshaft

## TROUBLESHOOTING

Engine		
Complaint	Symptom and possible causes	Remedy
<b>Engine is noisy</b>	<b>Noise seems to come from the piston</b>	
	Worn piston	Replace
	Worn cylinder	Rebore or replace
	Carbon build-up in combustion chamber	Clean
	Worn piston pin or piston pin bore	Replace
	Worn piston ring or ring groove	Replace
	<b>Noise seems to come from the cam chain</b>	
	Stretched cam chain	Replace cam chain and sprockets
	Worn cam chain sprocket	Replace cam chain and sprockets
	Improperly working cam chain tension adjuster	Repair or replace
	<b>Noise seems to come from the clutch</b>	
	Worn countershaft spline	Replace countershaft
	Worn clutch hub spline	Replace clutch hub
	Worn clutch plate teeth	Replace clutch plate
	Distorted clutch plate	Replace
	Worn clutch release bearing	Replace
	Weak clutch damper	Replace primary driven gear
	Weak clutch spring	Replace
	<b>Noise seems to come from the crankshaft</b>	
	Rattling bearing	Replace
	Worn or burnt crank pin bearing	Replace
	Worn or burnt ball bearing	Replace
	<b>Noise seems to come from the transmission</b>	
	Worn or rubbing gear	Replace
	Worn countershaft spline	Replace countershaft
	Worn driveshaft spline	Replace driveshaft
	Worn or rubbing primary gear	Replace
Worn bearing	Replace	
<b>Clutch slips</b>	Clutch cable out of adjustment	Adjust
	Weak or broken clutch spring	Replace
	Worn or distorted clutch pressure plate	Replace
	Distorted clutch plate	Replace
<b>Clutch drags</b>	Clutch out of adjustment	Adjust
	Some clutch springs are weak, while others are not	Replace
	Worn or distorted clutch pressure plate	Replace
	Distorted clutch plate	Replace
<b>Transmission will not shift</b>	Broken gearshift cam	Replace
	Distorted gearshift fork	Replace
	Worn gearshift fork pawl	Replace gearshift fork
<b>Transmission will not shift back</b>	Broken gearshift shaft return spring	Replace
	Rubbing or stuck gearshift shaft	Repair or replace
	Worn or distorted gearshift fork	Replace

## TROUBLESHOOTING

Engine		
Complaint	Symptom and possible causes	Remedy
<b>Transmission jumps out of gear</b>	Worn gear	Replace
	Worn or distorted gearshift fork	Replace
	Weakened gearshift stopper spring	Replace
	Worn gearshift fork pawl	Replace gearshift fork
<b>Engine idles poorly</b>	Tappet clearance out of adjustment	Adjust
	Improper valve seating	Repair or replace
	Worn valve guide	Replace
	Worn cam surface	Replace
	Excessive spark plug gap	Adjust or replace
	Defective ignition coil	Replace
	Defective pick-up coil or CDI unit	Replace
	Spark plug too cold	Replace by hot type plug
	Incorrect float Chamber fuel level	Adjust float height
	Clogged carburetor jet	Clean
	Defective generator	Replace
<b>Engine runs poorly in high-speed range</b>	Weak valve spring	Replace
	Worn camshaft	Replace
	Insufficient spark plug gap	Regap or replace
	Ignition not advanced sufficiently due to poorly working timing advance circuit	Replace CDI unit
	Defective ignition coil	Replace
	Defective pick-up coil or CDI unit	Replace
	Low float chamber fuel level	Adjust float height
	Dirty air cleaner element	Clean or replace
	Clogged fuel hose, resulting in inadequate fuel supply to carburetor	Clean and prime
<b>Exhaust smoke is dirty or thick</b>	Excessive amount of engine oil	Check level and drain
	Worn cylinder	Rebore or replace
	Worn piston ring	Replace
	Worn valve guide	Replace
	Scored or scuffed cylinder wall	Rebore or replace
	Worn valve stem	Replace valve
	Defective valve stem oil seal	Replace
	Worn oil ring side rail	Replace oil ring

## TROUBLESHOOTING

Engine		
Complaint	Symptom and possible causes	Remedy
<b>Engine lacks power</b>	Insufficient tappet clearance	Adjust
	Weak valve spring	Replace
	Mistimed valves	Adjust
	Worn cylinder	Rebore or replace
	Worn piston ring	Replace
	Improper valve seating	Repair or replace
	Fouled spark plug	Clean or replace
	Incorrect spark plug	Replace
	Clogged carburetor jet	Clean
	Incorrect float chamber fuel level	Adjust float height
	Dirty air cleaner element	Clean or replace
	Worn camshaft	Replace
	Air leakage from intake pipe	Tighten or replace
	Excessive amount of engine oil	Check level and drain
<b>Engine overheats</b>	Carbon build-up on piston crown	Clean
	Insufficient amount of engine oil	Check level and add
	Defective oil pump	Replace
	Clogged oil circuit	Clean
	Float chamber fuel level too low	Adjust float height
	Air leakage from intake pipe	Tighten or replace
	Incorrect engine oil	Change
<b>Carburetor</b>		
<b>Starting difficulty</b>	Clogged starter jet	Clean
	Clogged starter jet passage	Clean
	Air leaking from joint between starter body and carburetor	Tighten, adjust or replace gasket
	Air leaking from carburetor joint or vacuum hose joint	Tighten or replace defective part
	Improperly working starter plunger	Adjust
<b>Idling or low-speed trouble</b>	Clogged or loose pilot jet	Clean or tighten
	Clogged or loose pilot air jet	Clean or tighten
	Air leaking from carburetor joint or vacuum pipe joint, or starter	Tighten or replace defective part
	Clogged pilot outlet port	Clean
	Clogged bypass port	Clean
	Starter plunger not fully closed	Adjust
<b>Medium-or high speed trouble</b>	Clogged main jet	Clean
	Clogged main air jet	Clean
	Clogged needle jet	Clean
	Improperly working throttle valve	Adjust
	Clogged fuel filter	Clean or replace
<b>Overflow and fuel level fluctuations</b>	Worn or damaged needle valve	Replace
	Broken needle valve spring	Replace
	Improperly working float	Adjust or replace
	Foreign matter on the needle valve	Clean or replace with needle valve seat
	Incorrect float chamber fuel level	Adjust float height



## TROUBLESHOOTING

Electric		
Complaint	Symptom and possible causes	Remedy
<b>No sparking or poor sparking</b>	Defective ignition coil	Replace
	Defective spark plug	Replace
	Defective pick-up coil	Replace
	Defective CDI unit	Replace
<b>Spark plug is wet or quickly becomes fouled with carbon</b>	Excessively rich air/fuel mixture	adjust carburetor
	Excessively high idling speed	Adjust carburetor
	Incorrect gasoline	Change
	Dirty air cleaner element	clean or replace
	Incorrect spark plug (cold type)	Change to hot type spark plug
<b>Spark plug quickly becomes fouled with oil or carbon</b>	Worn piston ring	Replace
	Worn piston	Replace
	Worn cylinder	Rebore or replace
	Excessive valve-stem-to-valve-guide clearance	Replace
	Worn valve stem oil seal	Replace
<b>Spark plug electrodes overheat or burn</b>	Incorrect spark plug (hot type)	Change to cold type spark plug
	Overheated engine	Tune-up
	Loose spark plug	Tighten
	Excessively lean air/fuel mixture	Adjust carburetor
<b>Generator does not charge</b>	Open or short in lead wires, or loose lead connections	Repair, replace or connect properly
	Shorted, grounded or open stator coil	Replace
	Shorted or punctured regulator/rectifier	Replace
<b>Generator charges but charging rate is below the specifications</b>	Lead wires tend to get shorted or open-circuited or loosely connected at terminal	Repair or tighten
	Grounded or open-circuited stator coils or generator	Replace
	Defective regulator/rectifier	Replace
	Defective battery cell plates	Replace battery
<b>Generator overcharges</b>	Internal short-circuit in the battery	Replace battery
	Damaged or defective regulator/rectifier	Replace
	Poorly grounded regulator/rectifier	Clean and tighten ground connection
<b>Unstable charging</b>	Lead wire insulation frayed due to vibration resulting in intermittent shorting	Repair or replace
	Internally shorted generator	Replace
	defective regulator/rectifier	Replace
<b>Starter button does not work</b>	Run down battery	Recharge or replace
	Defective switch contact	Replace
	Brushes do not seat properly on the commutator in the starter motor.	Repair or replace
	Defective starter relay	Replace

## TROUBLESHOOTING

<b>Electric</b>		
<b>Complaint</b>	<b>Symptom and possible causes</b>	<b>Remedy</b>
Some electric components are without function, for instance indicator lamps, horn, starter	Faulty connection at the round plugs	Secure a correct contact by straighten the plugs
	Cold soldered points at the handlebar switch	Exchange the handlebar switches or solder the contacts again
	Faulty plugs at the ignition switch	Secure a correct contact
Rear indicator wire blown. Might concern the first series production	Pole at the indicator wire mix up	Exchange indicator lamps and connect correctly
Fuse blown	Short- circuit at the cable	Search for short- circuit and repair
Failure of the complete electric system	Battery to frame body without ground contact	Repair ground contact to the frame body
	Fuse blown or without contact	Change fuse and find out the reason
Indicator and rear light indicate with interplay	Battery is not charged, voltage below 10 V	Charge battery
	Indicator wire with low ground	Secure the isolation
Light gets darker if the turn light is active	A certain voltage is normal and can not be repaired	
	Battery voltage below 12 V	Recharge battery. Check if the battery will be charged by running engine
Head light bulbs blown all the time. Only for vehicles without clutch switch!	Diode defect or without contact	Remove the diode and connect the contacts so that the regulator can adjust the voltage
Light power too low	After all remedies the standard bulb is still too weak	Install a high beam bulb Caution! Not licensed for use on normal traffic conditions
Starter motor without function	Starter relay defect	Change starter relay
Speedometer without function	Batteries run down	Change batteries (AG 13)
	Batteries run down (about two weeks)	Change speedometer
	Moisture gets in the speedometer	Change speedometer
Rear light without function	Several LED with poor soldered points	Change complete LED rear light

## TROUBLESHOOTING

Battery		
Complaint	Symptom and possible causes	Remedy
Sulfation or spots on surfaces of cell plates	Cracked battery case	Replace the battery
	Battery has been left in an run-down condition for a long time	Replace
Battery runs down permanent	Contact to the regulator are loose	Secure a correct contact
	Diode blown or without contact Only for vehicles without clutch switch!	Remove diode and combine contacts so that the regulator can regulate the voltage
	Regulator defect	Check, if the board voltage increases during running engine. Replace regulator if necessary
	Battery defect	Replace the battery if it can not be charged
Battery runs down quickly	Incorrect charging method	Check generator, IC regulator, or rectifier circuit, connections, and make necessary adjustment to obtain specified charging operation
	Battery cell plates have lost much of their active material as a result of overcharging	Replace battery and correct charging system
	Internally shorted battery	Replace
	Excessively low battery voltage	Recharge
	Battery is too old	Replace
Battery sulfation	Incorrect charging rate (When not in use, the battery should be checked at least once a month and properly charged if necessary, to avoid sulfation.)	Replace battery
	The battery was left unused in a cold climate for too long	Replace the battery if badly sulfated